

OWNER'S MANUAL

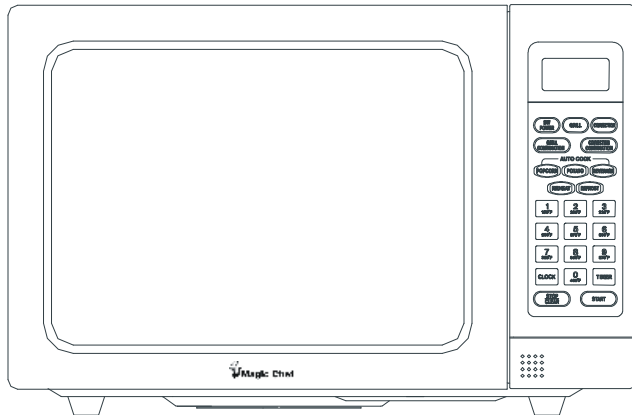

1.0 cu.ft Convection Microwave Oven

MCC1010STG



CONVECTION COOKING REDUCES COOKING TIMES

To take full advantage of the multi-purpose Magic chef Convection microwave oven, please read your instruction manual carefully before operating the oven.

PRECAUTIONS TO AVOID POSSIBLE EXPOSURE TO EXCESSIVE MICROWAVE ENERGY

- (a) Do not attempt to operate this oven with the door-open since open-door operation can result in harmful exposure to microwave energy. It is important not to defeat or tamper with the safety interlocks.
- (b) Do not place any object between the oven front face and the door or allow food debris or cleaner residue to accumulate on sealing surfaces.
- (c) Do not operate the oven if it is damaged. It is particularly important that the oven door close properly and that there is no damage to the:
 - Door (bent),
 - Hinges and latches (broken or loosened),
 - Door seals and sealing surfaces.
- (d) The oven should not be adjusted or repaired by anyone except properly qualified service personnel.

CONTENTS

IMPORTANT SAFETY INSTRUCTIONS.....	2
INSTALLATION GUIDE	4
GROUNDING INSTRUCTIONS	4
UTENSILS GUIDE.....	5
COOKING TECHNIQUES	6
BEFORE YOU CALL FOR SERVICE.....	8
SPECIFICATIONS	8
PART NAMES.....	8
ACCESSORIES.....	9
CONTROL PANEL.....	10
HOW TO SET THE OVEN CONTROLS.....	11
SPECIAL FEATURES.....	16
CLEANING AND CARE.....	19

IMPORTANT SAFETY INSTRUCTIONS

When using electrical appliances, basic safety precautions should be followed, including the following:

WARNING - To reduce the risk of burns, electric shock, fire, injury to persons or exposure to excessive microwave energy:

1. Read all instructions before using the appliance.
2. Read and follow the specific "PRECAUTIONS TO AVOID POSSIBLE EXPOSURE TO EXCESSIVE MICROWAVE ENERGY" on page 1.
3. This appliance must be grounded. Connect only to properly grounded outlet. See "grounding instructions" on page 4.
4. Install or locate this appliance only in accordance with the provided installation instructions.
5. Some products such as whole eggs and sealed containers -for example, closed glass jars- are able to explode and should not be heated in this oven.
6. Use this appliance only for its intended use as described in this manual. Do not use corrosive chemicals or vapors in this appliance. This type of oven is specifically designed to heat, cook, or dry food. It is not designed for industrial or laboratory use.
7. As with any appliance, close supervision is necessary when used by children.
8. To reduce the risk of fire in the oven cavity:
 - a. Do not overcook food. Carefully monitor appliance when paper, plastic, or other combustible materials are placed inside the oven to facilitate cooking.
 - b. Remove wire twist-ties from paper or plastic bags before placing bag in oven.
 - c. If materials inside the oven should ignite, keep oven door closed, turn oven off, and disconnect the power cord or shut off power at the fuse or circuit breaker panel.
 - d. Do not use the cavity for storage purposes. Do not leave paper products, cooking utensils or food in the cavity when not in use.
9. Liquids, such as water, coffee, or tea are able to be overheated beyond the boiling point without appearing to be boiling due to surface tension of the liquid. Visible bubbling or boiling when the container is removed from the microwave oven is not always present. **THIS COULD RESULT IN VERY HOT LIQUIDS SUDDENLY BOILING OVER WHEN A SPOON OR OTHER UTENSIL IS INSERTED INTO THE LIQUID.** To reduce the risk of injury to person:

SAVE THESE INSTRUCTIONS

- a. Do not overheat the liquid.
 - b. Stir the liquid both before and halfway through heating it.
 - c. Do not use straight-sided containers with narrow necks.
 - d. After heating, allow the container to stand in the microwave oven for a short time before removing the container.
 - e. Use extreme care when inserting a spoon or other utensil into the container.
10. Do not heat oil or fat for deep-frying. It is difficult to control the temperature of oil in microwave oven.
 11. Pierce foods with heavy skins such as potatoes, whole squash, apples and chestnuts before cooking.
 12. The contents of feeding bottles and baby jars should be stirred or shaken and the temperature should be checked before serving in order to avoid burns.
 13. Cooking utensils may become hot because of heat transferred from the heated food. Potholders may be needed to handle the utensil.
 14. Do not cover or block any openings on the appliance.
 15. Do not store or use this appliance outdoors. Do not use this product near water, for example, near a kitchen sink, in a wet basement, near a swimming pool, or similar locations.
 16. Do not operate this appliance if it has a damaged cord or a plug, if it is not working properly or if it has been damaged or dropped.
 17. Do not immerse cord or plug in water. Keep cord away from heated surface. Do not let cord hang over edge of table or counter.
 18. Use only thermometers, which are specifically designed for use in microwave ovens.
 19. Do not operate any heating or cooking appliance beneath this appliance.
 20. Be certain the glass tray and roller rings are in place when you operate the oven.
 21. **WARNING:** It is hazardous for anyone other than a trained person to carry out any service or repair operation, which involves the removal of any cover, which gives protection against exposure to microwave energy. If there is any damage, do not operate the oven and contact MC Appliance Corp. for service.
 22. When cleaning surfaces of door and oven that comes together on closing the door, use only mild, nonabrasive soaps, or detergents applied with a sponge or soft cloth.

SAVE THESE INSTRUCTIONS

INSTALLATION GUIDE

1. Make sure that all the packing materials are removed from the inside of the door.
2. Check the oven for any damage, such as misaligned or bent door, damaged door seals and sealing surface, broken or loose door hinges and latches and dents inside the cavity or on the door. If there is any damage, do not operate the oven but contact qualified service personnel.
3. This microwave oven must be placed on a flat, stable surface to hold its weight and the heaviest food likely to be cooked in the oven.
4. Do not place the oven where heat, moisture, or high humidity are generated, or near combustible materials.
5. For correct operation, the oven must have sufficient airflow. Allow 8 inches of space above the oven, 4 inches at back and 2 inches at both sides. Do not cover or block any openings on the appliance. Do not remove feet on which oven stands.
6. Do not operate the oven without glass tray, roller support, and shaft in their proper positions.
7. Make sure that the power supply cord is undamaged and does not run under the oven or over any hot or sharp surface.
8. The socket must be readily accessible so that it can be easily unplugged in an emergency.

GROUNDING INSTRUCTIONS

This appliance must be grounded. In the event of an electrical short circuit, grounding reduces risk of electric shock by providing an escape wire for the electric current.

WARNING: Improper use of the grounding plug can result in a risk of electric shock.

Electrical Requirements

The electrical requirements are a 120 volt 60 Hz, AC only, 20 amp. It is recommended that a separate circuit serving only the oven be provided. The oven is equipped with a 3-prong grounding plug. It must be plugged into a wall receptacle that is properly installed and grounded. This unit is not designed for recreational vehicles.

Power Supply Cord

1. A short power supply cord is provided to reduce the risks resulting from becoming entangled in or tripping over a longer cord.

SAVE THESE INSTRUCTIONS

2. If long cord or extension cord is used□
 - a) The marked electrical rating of the cord set or extension cord should be at least as great as the electrical rating of the appliance.
 - b) The extension cord must be a grounding-type 3-wire cord, and The longer cord should be arranged so that it will not drape over the counter top or table top where it can be pulled on by children or tripped over unintentionally.

Notes:

1. If you have any questions about the grounding or electrical instructions, consult a qualified electrician or service person.
2. Neither MC Appliance Corp nor the dealer can accept any liability for damage to the oven or personal injury resulting from failure to observe the electrical connection procedures.

UTENSILS GUIDE

This section lists which utensils can be used in the microwave, which ones have limited use for short periods, and which ones should not be used in the microwave.

Recommended

- Microwave browning dish** — Use to brown the exterior of small items such as steaks, chops, or pancakes. Follow the directions provided with your browning dish.
- Microwaveable plastic wrap** — Use to retain steam. Leave a small opening for some steam to escape and avoid placing it directly on the food.
- Paper towels and napkins** — Use for short-term heating and covering; these absorb excess moisture and prevent spattering. Do not use recycled paper towels, which may contain metal and could ignite.
- Glass and glass-ceramic bowls and dishes** — Use for heating or cooking.
- Paper plates and cups** — Use for short-term heating at low temperatures. Do not use recycled paper, which may contain metal and could ignite.
- Wax paper** — Use as a cover to prevent spattering.
- **Thermometers** — Use only those labeled “Microwave Safe” and follow all directions. Check the food in several places. Conventional thermometers may be used on microwave food once the food has been removed from the oven.

SAVE THESE INSTRUCTIONS

Limited Use

- **Aluminum foil** — Use narrow strips of foil to prevent overcooking of exposed areas. Using too much foil can damage your oven, so be careful.
- **Ceramic, porcelain, and stoneware** — Use these if they are labeled “Microwave Safe”. If they are not labeled, test them to make sure they can be used safely.
- **Plastic** — Use only if labeled “Microwave Safe”. Other plastics can melt.
- **Straw, wicker, and wood** — Use only for short-term heating, such as warming dinner rolls for a few seconds; baskets and bowls may be flammable.

Not Recommended

- **Glass jars and bottles** — Regular glass is too thin to be used in a microwave. It can shatter and cause damage and injury.
- **Paper bags** — These are a fire hazard, except for popcorn bags that are designed for microwave use.
- **Styrofoam plates and cups** — These can melt and leave an unhealthy residue on food.
- **Plastic storage and food containers** — Containers such as margarine tubs can melt in the microwave.
- **Metal utensils** — These can damage your oven. Remove all metal before cooking.

The list below is a general guide to help you select the correct utensils.

Cookware	Microwave	Grill	Convection	Combination
Heat-Resistant Glass (Glass tray)	Yes	Yes	Yes	Yes
Non Heat-Resistant Glass	No	No	No	No
Heat-Resistant Ceramics	Yes	Yes	Yes	Yes
Microwave-Safe Plastic Dish	Yes	No	No	No
Kitchen Paper	Yes	No	No	No
Metal Tray	No	Yes	Yes	Yes
Metal Rack	No	Yes	Yes	No
Aluminum Foil & Foil Container	No	Yes	Yes	No

SAVE THESE INSTRUCTIONS
COOKING TECHNIQUES

Your microwave makes cooking easier than conventional cooking, provided you keep these considerations in mind:

Stirring

Stir foods such as casseroles and vegetables while cooking to distribute heat evenly. Food at the outside of the dish absorbs more energy and heats more quickly, so stir from the outside to the center. The oven will turn off when you open the door to stir your food.

Arrangement

Arrange unevenly shaped foods, such as chicken pieces or chops, with the thicker, meatier parts toward the outside of the turntable where they receive more microwave energy. To prevent overcooking, place delicate areas, such as asparagus tips, toward the center of the turntable.

Shielding

Shield food with narrow strips of aluminum foil to prevent overcooking. Areas that need shielding include poultry wing-tips, the ends of poultry legs, and corners of square baking dishes. Use only small amounts of aluminum foil. Larger amounts can damage your oven.

Turning

Turn foods over midway through cooking to expose all parts to microwave energy. This is especially important with large foods such as roasts.

Standing

Foods cooked in the microwave build up internal heat and continue to cook for a few minutes after heating stops. Let foods stand to complete cooking, especially foods such as cakes and whole vegetables. Roasts need this time to complete cooking in the center without overcooking the outer areas. All liquids, such as soup or hot chocolate, should be shaken or stirred when cooking is complete. Let liquids stand a moment before serving. When heating baby food, stir well at removal and test the temperature before serving.

Adding moisture

Microwave energy is attracted to water molecules. Food that is uneven in moisture content should be covered or allowed to stand so that the heat disperse evenly. Add a small amount of water to dry food to help it cook.

SAVE THESE INSTRUCTIONS

BEFORE YOU CALL FOR SERVICE

If the oven fails to operate:

- A) Check to ensure that the oven is plugged in securely. If it is not, remove the plug from the outlet, wait 10 seconds and plug it in again securely.
- B) Check for a blown circuit fuse or a tripped main circuit breaker. If these seem to be operating properly, test the outlet with another appliance.
- C) Check to ensure that the control panel is programmed correctly and the timer is set.
- D) Check to ensure that the door is securely closed engaging the door safety lock system. Otherwise, the microwave energy will not flow into the oven.

If none of the above rectify the situation. Please visit our website at www.magicchef-ewave.com to request service or contact our customer support dept. at (888) 775-0202.

SPECIFICATIONS

Power Consumption:	120V, 60Hz, 1450W (Microwave)
	120V, 1400W (Convection)
	120V, 1400W (Grill)
Rated Microwave Output:	1000W
Operation Frequency:	2450MHz
Outside Dimensions:	12"(H)×20 11/16"(W)×19 5/16"(D)
Cavity Dimensions:	8 5/8"(H)×13 3/4"(W)×14"(D)
Net Weight:	Approx. 48.5lbs

PART NAMES

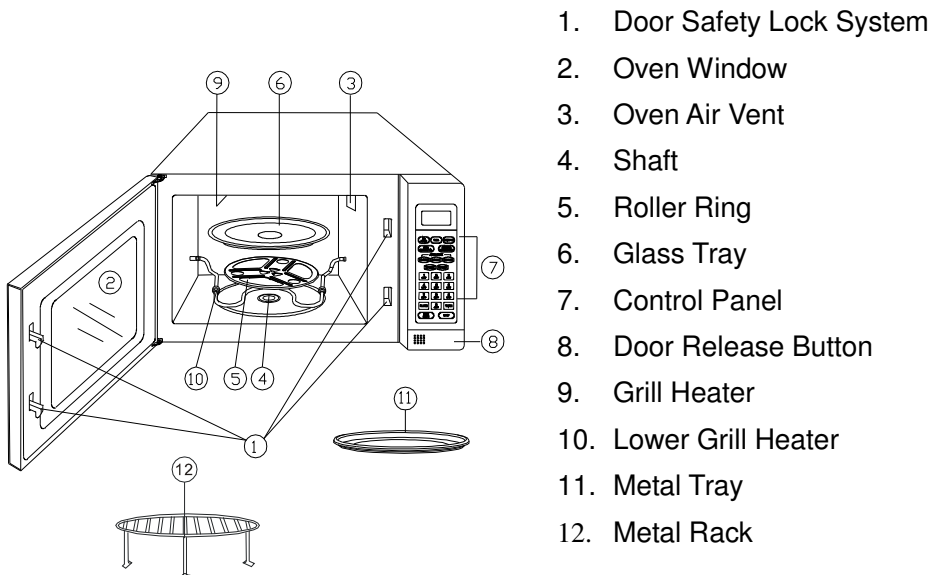

ACCESSORIES

This oven comes equipped with several accessories. They can be used in various ways to facilitate cooking.

- **Roller ring & Glass tray**

These fit over the shaft in the center of the oven's cavity floor.

These parts should remain in the oven at all times.

They should only be removed for cleaning.

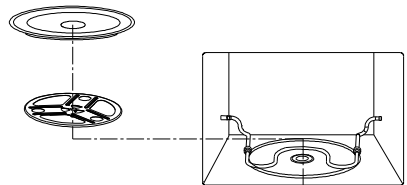

- **Metal tray**

The metal tray fits over the glass tray and locks into place.

This is to be used in the oven for grill, convection and combination cooking. It rotates clockwise or counterclockwise during cooking.

It is easily removable for cooking and cleaning needs.

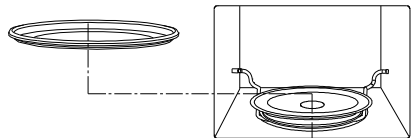

- **Metal Rack**

This metal rack is used in the oven for grill and convection cooking.

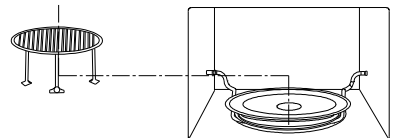

IMPORTANT:

1. The Roller ring and Glass tray must be placed in the center of the oven's cavity and fitted in the shaft exactly.
2. Metal rack and metal tray cannot be used together under combi cooking.

SAVE THESE INSTRUCTIONS

CONTROL PANEL

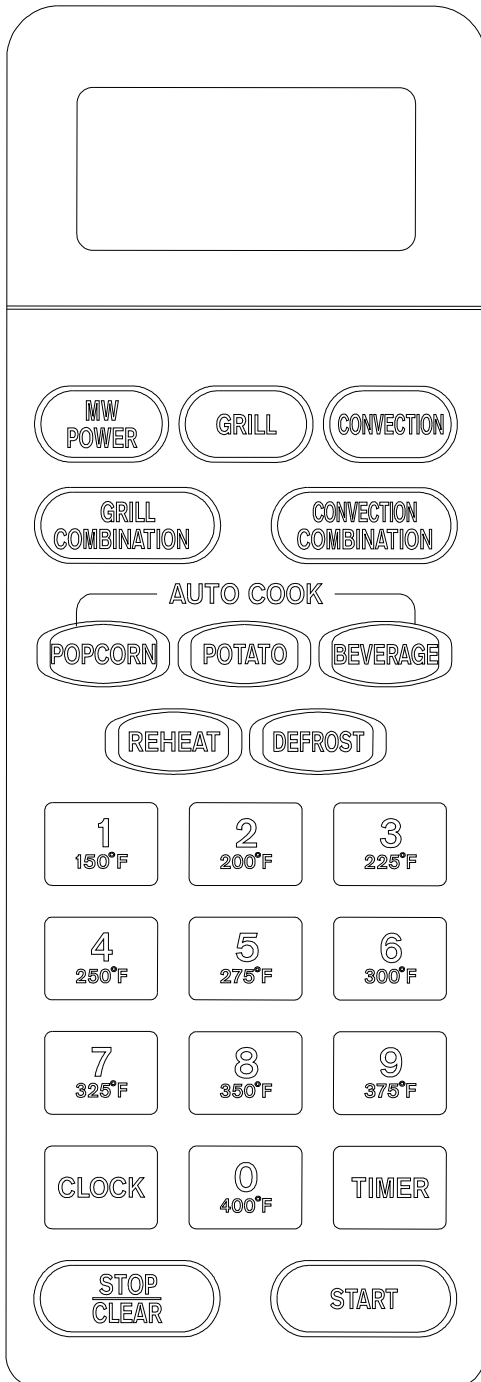

DISPLAY SCREEN

Cooking time, power, indicators and present time are displayed.

MW POWER

Touch MW POWER and then use number pads to set cooking power level.

GRILL

Press to set a grill-cooking program.

CONVECTION

Press to program convection cooking.

GRILL COMBINATION

Touch to set a grill combination program.

CONVECTION COMBINATION

Touch to roast food

CLOCK

Use to set the clock

TIMER

Use to set the oven timer

AUTO COOK PADS

POPCORN REHEAT POTATO
BEVERAGE

DEFROST

Touch to defrost food

START

Press to start cooking.

STOP/CLEAR

Touch to stop cooking program or clear all previous settings before cooking starts

NUMBER PADS/CONVECTION TEMPERATURE ENTRY

Touch to set cooking time, enter weight or number of servings, or program convection temperature.

(Please also see the following pages for more detail)

HOW TO SET THE OVEN CONTROLS

BEEPS DURING OVEN SETTINGS

- ♦ ONE BEEP: Oven accepts the entry.
- ♦ TWO BEEPS: Oven does not accept the entry. Please check and try again.

SETTING THE CLOCK

When the oven is first plugged in, the display will briefly show “ENTER”, “CLOCK”, “TIME”, you can set the clock time now or later. To set the clock time later,

CLOCK

1. Press CLOCK pad.

NOTE: The clock works in 12-hour cycle.

2. Use the numeric pads (in the natural sequence of time) to enter clock time

The display stops blinking, and the colon starts blinking. This digital clock allows you to set from 1:00 to 12:59.

3. Press CLOCK to confirm.

MICROWAVE COOKING

**MW
POWER**

1. Press MW
POWER pad.

(Select the desired power level.)

The “MICRO” indicator lights and “P-H1” is displayed

The display will show entered power level.

2. Press number pads to enter cooking time until the correct cooking time is displayed.

NOTE: If step 1 is omitted, the oven will cook at full power.

The display will show entered cooking time.

3. Press START pad.

NOTE: You oven can be programmed for 99 minutes 99 seconds. (99:99)

Microwave cooking allows you to customize cooking power and time. First, you select a power level by pressing the MW POWER pad a number of times (see the table below).

Then you set the cooking time using the numeric pads, before pressing the START pad.

NOTE: If you want to temporarily stop a cooking session, press the STOP/CLEAR pad once and then you can start the cooking again by press START; or press the STOP/CLEAR twice to cancel the cooking program altogether.

Press POWER pad to select cooking power		
Press	Power	Description
once	100%(P-HI)	High
twice	90%(P-90)	
3 times	80%(P-80)	
4 times	70%(P-70)	Medium High
5 times	60%(P-60)	
6 times	50%(P-50)	Medium
7 times	40%(P-40)	
8 times	30%(P-30)	Med. Low/Defrost
9 times	20%(P-20)	
10 times	10%(P-10)	Low
11 times	0%(P-00)	

GRILL

NOTE: Make sure the system is reset by pressing the STOP/CLEAR pad once before using Grill function.

GRILL

1. Press GRILL pad once. "ENTER", "COOK", "TIME", "GRILL" indicators light and symbol ":" will be displayed. The display will show entered cooking time.
2. Use the number pads to enter cooking time. The display will show entered cooking time.
3. Press START pad.

NOTE: You oven can be programmed for 99 minutes 99 seconds. (99:99)

Grill cooking is particularly useful for thin slices of meat, steaks, chops, kebabs, sausages and pieces of chicken. It is also suitable for hot sandwiches and au gratin dishes.

GRILL COMBINATION

**GRILL
COMBINATION**

1. Press GRILL COMBINATION button once or twice.

“GRILL”, “MICRO” indicators light and “C-1” or “C-2” is displayed.

NOTE: COMBINATION 1 (C-1)
30% time for microwave cooking. 70% time for grill cooking. Use for fish, potatoes, or au gratin.
COMBINATION 2 (C-2)
55% time for microwave cooking. 45% time for grill cooking. Use for cooking pudding omelets, baked potatoes, and poultry.

2. Use the number pads to enter cooking time.

The display will show what you touched.

3. Press START button.

NOTE: You oven can be programmed for 99 minutes 99 seconds. (99:99)

CONVECTION

During convection cooking, hot air is circulated throughout the oven cavity to brown and make crisp foods quickly and evenly. This oven can be programmed for ten different cooking temperatures (150°, 200°, 225°, 250°, 275°, 300°, 325°, 350°, 375°, 400°). Maximum cooking time for convection is 9 hours 99 minutes (9H: 99).

To Cook with Convection

To cook with convection, press CONVECTION pad once and then press the number pads to enter the desired convection temperature.

1. Press CONVECTION pad.

CONVECTION

light.

2. Press number pad 0~9 to Select the CONVECTION temperature.

The display will show the temperature you selected.

“ENTER”, “CODE”, “CONV” indicators

3. Press number pads to enter cooking time.

4. Press START pad.

time.

NOTE: You can check the convection temperature while cooking is in progress by pressing the CONVECTION pad.

The display will show entered cooking

To Preheat and Cook with Convection

Your oven can be programmed to combine preheating and convection cooking operations.

1. Press CONVECTION button.

CONVECTION

“ENTER”, “CODE”, “CONV” indicators light.

2. Press number pad 0~9 to select the temperature.

“ENTER”, “TIME”, “COOK”, “CONV” indicators light and selected temperature is displayed.

3. Press START pad.

NOTE: Beeps will sound when the designated temperature is reached.

4. Open the door and place container of food at the center of the turntable.

5. Use the number pads to enter cooking time.

The display will show entered cooking time

6. Press START pad.

“CONV”, “COOK” and cooking time will be displayed.

Note: 1. The preheat time cannot be set.
2. The cavity temperature will keep stable after reaching the setting temperature for 30 minutes.

CONVECTION COMBINATION

This oven has four pre-programmed settings that make it easy to cook with both convection heat and microwave whereby meats can be made juicy and tender with just the right amount of browning and crispness.

Press CONVECTION COMBINATION pad and then use the number pads 1-4 to

program convection temperature:

**CONVECTION
COMBINATION**

Program	Press number pad	Temp. (□)
COMB1	1	250
COMB2	2	300
COMB3	3	350
COMB4	4	400

1. Press CONVECTION COMBINATION pad. "ENTER", "CODE", "CONV", "MICRO" indicators light and ": " is displayed.
2. Use the number pads 1-4 to enter convection temperature. The display will show the temperature you touched.
3. Use the number pads to enter cooking time. The display will show entered cooking time.
4. Press START pad to start.

NOTE: Maximum cooking time for convection combination is 9 hours 99 minutes (9H:99).

NOTE: You can check the convection cooking power while cooking is in progress by pressing the CONVECTION COMBINATION pad.

DEFROST

DEFROST

1. Press DEFROST pad. "ENTER", "TIME", "DEF" indicators light and ": " is displayed.
2. Use the number pads to enter defrosting time. The display will show entered cooking time.
3. Press START pad.

NOTE: Maximum cooking time for defrost is 99 minutes 99 seconds (99:99).

MULTI-STAGE COOKING

Your oven can be programmed for up to 3 automatic cooking sequences. DEFROST can

only be selected before the cooking stage in a program.

FOR EXAMPLE: Suppose you want to set the following cooking program.

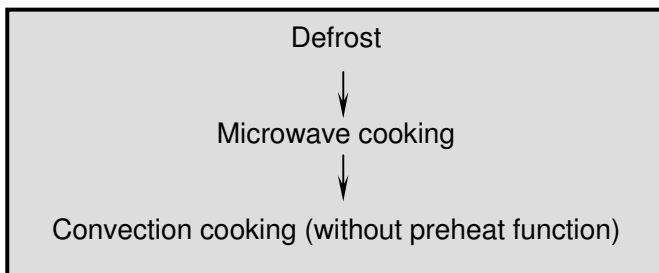

DEFROST

1. Press DEFROST pad.
2. Use the number pads to enter defrosting time.
3. Press MW POWER button to set power level.
4. Use the number pads to enter cooking time.
5. Press CONVECTION pad.
6. Use the number pads to program convection temperature.
7. Use the number pads to enter convection cooking time.
8. Press START button.

SPECIAL FEATURES

In this special feature section, you can find easy settings to cooking popular food.

POPCORN

This feature allows a regular sized bag (99g or approximately 3.5oz) of popcorn to be popped.

1. Press POPCORN pad once.

POPCORN

2. Press START pad.

“ENTER”, “AMT” indicators light and preprogrammed amount “3.50” is displayed.

“CODE”, “COOK”, “MICRO” indicators light, preprogrammed cooking time “2:50” is displayed and display counts down the time remaining.

NOTE: Popping time can vary from 2~4 minutes according to brand of popcorn.

CAUTION: Do not place bag directly on the turntable tray, place bag on microwavable dish when cooking.

POTATO

1. Touch POTATO pad up to 3 times to select number of servings (about 7~9 oz per serving).

POTATO

2. Press START pad.

NOTE: After the cooking program have finished, let food stand in the oven for 5~10 minutes.

“CODE”, “COOK”, “MICRO” indicators light and cooking time is displayed

BEVERAGE

1. Touch BEVERAGE pad up to 3 times to select the number of servings (7~9 oz per serving)

BEVERAGE

2. Touch START pad.

“CODE”, “COOK”, “MICRO” indicators light and cooking time is displayed.

REHEAT

1. Press REHEAT pad once or up to 7 times to select weight (7~28oz).

REHEAT

2. Press START pad.

“ENTER”, “ATM” indicators light and selected preprogrammed weight is displayed.

“CODE”, “COOK”, “MICRO” indicators light and cooking time is displayed.

NOTE: Touch the reheat pad will allow the reheating of a chilled dinner plate.

OTHER CONVENIENT FEATURES

MINUTE TIMER

The timer works independently as a reminder and the time countdown ends in beeping.

1. Press TIMER pad.

TIMER

“ENTER”, “ATM”, “MICRO” indicators light

and “:” will be displayed.

2. Use the numeric pads to enter the time to be counted down.

3. Press START pad.

The display will show entered time.

NOTE: The display will count down for 5 seconds and then back to the previous mode. You can check the residual time by press TIMER pad. 2 beeps will be sound when timer is end.

CHILD SAFETY LOCK

The lock prevents unsupervised operation by little children. To set the lock:

STOP/CLEAR s STOP/CLEAR pad for 3 seconds, then a beep will sound and the indicator light will come on. In the lock state, all pads are disabled.

To cancel the lock: Press STOP/CLEAR pad for 3 seconds, then a beep will sound and the indicator light will come off.

TO STOP THE OVEN WHILE THE OVEN IS OPERATING

1. Press STOP/CLEAR pad.

STOP/CLEAR

NOTE: You can restart the oven by pressing START pad. Touch STOP/CLEAR to erase all instructions.

2. Open the door.

NOTE: You can restart the oven by closing the door and pressing START pad.

=====

NOTE

If one of the following codes (E01, E02 or E03) appears in the display panel please press the stop/clear pad to turn off the unit. Please contact our customer support Dept for additional information at 888-775-0202 or via the web at www.magicchef-ewave.com

CLEANING AND CARE

1. Turn off the oven and remove the power plug from the wall socket before cleaning.
2. Keep the inside of the oven clean. When food splatters or spilled liquids adhere to oven walls, wipe with a damp cloth. Mild detergent may be used if the oven gets very dirty. Avoid the use of spray and other harsh cleaners as they may stain, streak or dull the door surface.
3. The outside surfaces should be cleaned with a damp cloth. To prevent damage to the operating parts inside the oven, water should not be allowed to seep into the ventilation openings.
4. Wipe the door and window on both sides, the door seals and adjacent parts frequently with a damp cloth to remove any spills or splatters. Do not use abrasive cleaner.
5. Do not allow the control panel to become wet. Clean with a soft, damp cloth. When cleaning the control panel, leave oven door open to prevent oven from accidentally turning on.
6. If steam accumulates inside or around the outside of the oven door, wipe with a soft cloth. This may occur when the microwave oven is operated under high humidity condition. And it is normal.
7. It is occasionally necessary to remove the glass tray for cleaning. Wash the tray in warm sudsy water or in a dishwasher.
8. The roller ring and oven floor should be cleaned regularly to avoid excessive noise. Simply wipe the bottom surface of the oven with mild detergent. The roller ring may be washed in mild sudsy water or dishwasher. When removing the roller ring from cavity floor for cleaning, be sure to replace in the proper position.
9. Remove odors from your oven by combining a cup of water with the juice and skin of one lemon in a deep microwaveable bowl, microwave for 5 minutes. Wipe thoroughly and dry with a soft cloth.
10. The oven should be cleaned regularly and any food deposits removed. Failure to maintain the oven in a clean condition could lead to deterioration of the surface that could adversely affect the life of the appliance and possibly result in a hazardous situation.
11. Please do not dispose this appliance into the domestic rubbish bin, it should be disposed to the particular disposal center provided by the municipalities.

SAVE THESE INSTRUCTIONS



Microwave Oven Warranty

MC Appliance Corp. warrants each new Microwave Oven to be free from defects in material and workmanship and agrees to remedy any such defect or to furnish a new part(s) (at the company's option) for any part(s) of the unit that has failed during the warranty period. Parts and labor expenses are covered on this unit for a period of one year after the date of purchase. In addition, MC Appliance Corp. warrants the Magnetron (parts only) to be free from defects in material and workmanship for a period of 8 years. The consumer is responsible for all labor and transportation expenses related to the diagnosis and replacement of the magnetron after the initial one- year warranty has expired. If in the event the unit requires replacement or refund under the terms of this warranty the consumer is responsible for all transportation expenses to return the unit to our factory prior to receiving a replacement unit or refund. **A copy of the dated sales receipt / invoice is required to receive warranty service.**

This warranty covers appliances in use within the continental United States, Puerto Rico and Hawaii. The warranty does not cover the following:

- Damages due to shipping damage or improper installation.
- Damages due to misuse or abuse.
- Content losses due to failure of the unit.
- Inside components such as door panels, door shelves, racks, light bulbs etc...
- Repairs performed by unauthorized service agents.
- Service calls that do not involve defects in material and workmanship such as instruction on proper use of the product, or improper installation.
- Replacement or resetting of house fuses or circuit breakers.
- Failure of this product if used for other than its intended purpose.
- Disposal costs of failed units not returned to our factory.
- Any delivery / installation costs incurred as the result of a unit that fails to perform as specified.

This warranty is in lieu of all warranties expressed or implied and no representative or person is authorized to assume for us any other liability in connection with the sale of this product. Under no circumstances is the consumer permitted to return this unit to the factory without prior written consent from MC Appliance Corp.

Model	Parts	Labor	Magnetron (Part Only)	Type of Service
MCC1010STG	One- Year	One- Year	Eight Years	Carry In

For Service or Assistance please call 888 775-0202 or visit us on the web at

www.mcappliance.com

Magic Chef is a trademark of the Maytag Corporation and is used under license to MC Appliance Corp. All rights reserved.