

SHARP

OPERATION MANUAL with COOKBOOK



R-248D MICROWAVE OVEN

800W (IEC 60705)

OPERATION MANUAL

This operation manual contains important information which you should read carefully before using your microwave oven.

IMPORTANT: There may be a serious risk to health if this operation manual is not followed or if the oven is modified so that it operates with the door open.

**If you require any advice or assistance regarding your Sharp product, please visit our website:
<http://www.sharp.co.uk/support>**

Customers without Internet access may telephone (during office hours):

08705 274277

**or from Ireland
(01) 676 0648**



Attention:

Your product is marked with this symbol.

It means that used electrical and electronic products should not be mixed with general household waste. There is a separate collection system for these products.

A. Information on Disposal for Users (private households)

1. In the European Union

Attention: If you want to dispose of this equipment, please do not use the ordinary dust bin! Used electrical and electronic equipment must be treated separately and in accordance with legislation that requires proper treatment, recovery and recycling of used electrical and electronic equipment.

Following the implementation by member states, private households within the EU states may return their used electrical and electronic equipment to designated collection facilities free of charge*.

In some countries* your local retailer may also take back your old product free of charge if you purchase a similar new one.

*) Please contact your local authority for further details.

If your used electrical or electronic equipment has batteries or accumulators, please dispose of these separately beforehand according to local requirements.

By disposing of this product correctly you will help ensure that the waste undergoes the necessary treatment, recovery and recycling and thus prevent potential negative effects on the environment and human health which could otherwise arise due to inappropriate waste handling.

2. In other Countries outside the EU

If you wish to discard this product, please contact your local authorities and ask for the correct method of disposal.

For Switzerland: Used electrical or electronic equipment can be returned free of charge to the dealer, even if you don't purchase a new product. Further collection facilities are listed on the homepage of www.swico.ch or www.sens.ch.

B. Information on Disposal for Business Users

1. In the European Union

If the product is used for business purposes and you want to discard it:

Please contact your SHARP dealer who will inform you about the take-back of the product. You might be charged for the costs arising from take-back and recycling. Small products (and small amounts) might be taken back by your local collection facilities.

For Spain: Please contact the established collection system or your local authority for take-back of your used products.

2. In other Countries outside the EU

If you wish to discard of this product, please contact your local authorities and ask for the correct method of disposal.

CONTENTS

OVEN AND ACCESSORIES	2
CONTROL PANEL	3
SAFETY:	
Installation	4 - 5
Important Safety Instructions	5
OPERATION:	
Maff Heating Category	6
How Your Oven Works	6
Microwave Power Levels	7
Before Operation	7
Setting the Clock	8
How to Operate Your Oven	9 - 10
Express Cook / Defrost	11 - 12
Express Cook Chart	13
Express Defrost Chart	13
Convenient Functions	14
COOKING ADVICE:	
Microwave Cooking Advice	15 - 16
Suitable Cookware	17
Defrosting Advice	18
Reheating Advice	19
COOKBOOK	20 - 32
AFTERCARE:	
Cleaning and Maintenance	33
Troubleshooting	34
To Replace the Mains Plug	35
Calling for Service	35
GUARANTEE	36
SPECIFICATIONS	37

OVEN AND ACCESSORIES

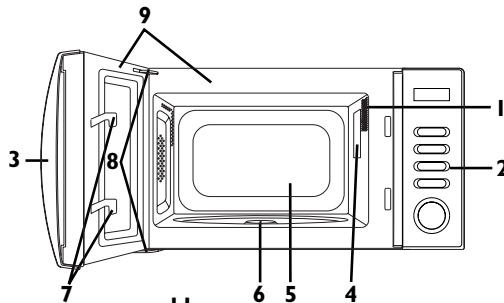

OVEN:

1. Oven lamp
2. Control panel
3. Door opening handle
4. Waveguide cover (DO NOT REMOVE)
5. Oven cavity
6. Coupling
7. Door latches
8. Door hinges
9. Door seals and sealing surfaces
10. Power cord
11. Ventilation openings
12. Outer cabinet

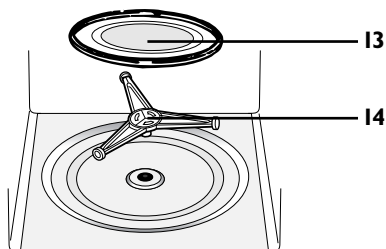
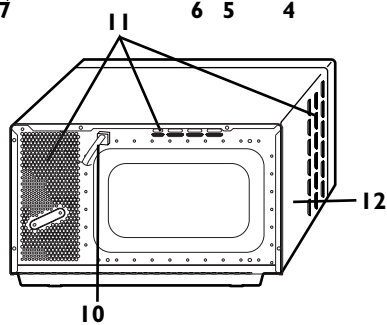

ACCESSORIES:

Check to make sure the following accessories are provided:

13. Turntable
14. Roller stay

- Place the roller stay in the coupling on the oven floor, then place the turntable on to the roller stay, ensuring it is located firmly.
- To avoid turntable damage, ensure dishes or containers are lifted clear of the turntable rim when removing them from the oven.

NOTES:

- The waveguide cover is fragile. Care should be taken when cleaning inside the oven to ensure that it is not damaged.
- Always operate the oven with the turntable and roller stay fitted correctly. This promotes thorough, even cooking. A badly fitted turntable may rattle, may not rotate properly and could cause damage to the oven.
- The turntable rotates clockwise or anti-clockwise. The rotary direction may change each time you start the oven. This does not affect cooking performance.
- When you order accessories, please quote both the **PART NAME** and **MODEL NUMBER** to your dealer or SHARP approved service facility.



WARNING:

The door, outer cabinet, oven cavity, turntable and dishes will become very hot during operation. To prevent burns, always use thick oven gloves.

CONTROL PANEL

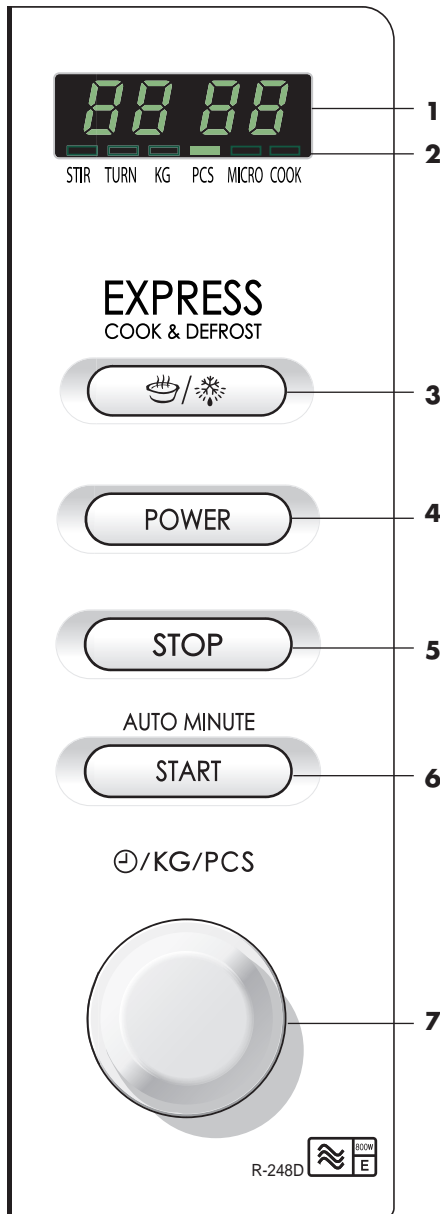

1. **DIGITAL DISPLAY**
2. **INDICATORS**
3. **EXPRESS COOK/DEFROST** button
4. **POWER LEVEL** button
5. **STOP** button
6. **START/AUTO MINUTE** button
7. **TIME/WEIGHT/PORTION** knob

INSTALLATION



WARNING:

Inspect the Oven:

- Check the oven carefully for damage before and regularly after installation.
- Make sure the door closes properly, that it is not misaligned or warped.
- Check the hinges and door safety latches are not broken or loose.
- Ensure the door seal and sealing surfaces are not damaged. If the door or door seals are damaged, the oven must not be operated until it has been repaired by a competent person.
- Inspect the oven interior and door for dents.

IMPORTANT:

If any damage is apparent, do not operate the oven in any way, until it has been repaired by a SHARP trained engineer.

1. Remove all packing materials including the feature sticker (if applicable). Do not remove the plastic film from the inside of the oven window as this protects it from dirt. The waveguide cover prevents food and grease from entering the waveguide area where it could cause damage. **DO NOT REMOVE THE WAVEGUIDE COVER.**
2. Place oven on a secure, level surface. Ensure it is strong enough to take the oven weight, plus the heaviest item likely to be cooked in the oven.
3. The minimum height of free space necessary above the top surface of the oven is 15cm.

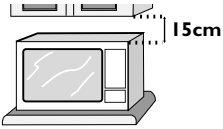
4. Do not place the oven where heat, moisture or high humidity are generated, (for example, near or above a conventional oven) or near combustible materials (for example, curtains). Do not block or obstruct air vent openings. Do not place objects on top of the oven.
5. Make sure the power supply cord is undamaged (See "ELECTRICAL CONNECTION" below).

Do not allow the power supply cord to run over any hot or sharp surfaces, such as the hot air vent area at the top rear of the oven.
6. The socket must be readily accessible so that it can be easily unplugged in an emergency.
7. Do not use the oven outdoors.

BUILDING-IN-KIT.

No built-in kit is available for this oven.

This oven is designed to be used on a countertop only.

ELECTRICAL CONNECTION.

- Do not allow water to come into contact with the power supply cord or plug.
- Insert the plug properly into the socket.
- Do not connect other appliances to the same socket using an adaptor plug.
- If the power supply cord is damaged, it must be replaced by a Sharp approved service facility or a similarly qualified person to avoid a hazard.
- When removing the plug from the socket always grip the plug, never the cord as this may damage the power supply cord and the connections inside the plug.
- If the plug fitted to your oven is a rewirable type and in the event of the socket outlet in your home not being compatible with the plug supplied, remove the plug properly (do not cut off).
- If the plug fitted to your oven is a non-rewirable type and in the event of the socket outlet in your home not being compatible with the plug supplied, cut-off the mains plug.
- Refit with a suitable type, observing the wiring code given in 'To replace the mains plug' on page 35.

INSTALLATION

IMPORTANT!

- The fuse from the cut-off plug should be removed and the plug disposed of in a safe manner.
- Under no circumstances should the cut-off plug be inserted into a socket outlet as a serious electric shock may occur.
- The plug must not be used without the fuse cover fitted.
- If you have any doubt about your microwave oven obtain the help of a qualified electrician.
- When replacing the plug please ensure that you use a BSI or ASTA approved plug to BS1363, this should be fitted with a brown coloured 13 amp fuse approved by BSI or ASTA to BS1362. If you have any doubt about electrical connection seek the help of a qualified electrician.



WARNING: THIS APPLIANCE MUST BE EARTHED

To wire an appropriate plug, follow the wiring code given in 'To replace the mains plug' on page 35.

IMPORTANT SAFETY INSTRUCTIONS

PLEASE READ CAREFULLY AND KEEP FOR FUTURE REFERENCE

Oven Use:

- The oven is for domestic food use only.
- Never operate the oven when empty.
- Do not leave or store anything inside the oven when not in use.
- Never attempt to use the oven with the door open. It is important not to force or tamper with the door safety latches.
- Never operate the oven with any object caught in the door.
- Do not insert fingers or objects in the holes of the door latches or air-vent openings as this may damage the oven and cause an electric shock.
- If water or food drops inside the air vent openings switch off the oven immediately, unplug it and call a SHARP approved service facility. (See page 35).
- Never move the oven while it is operating.

Pacemaker: If you have a heart pacemaker, consult your doctor or the pacemaker manufacturer prior to oven use.

WARNING: Only allow children to use the oven without supervision when adequate instructions have been given so that the child is able to use the oven in a safe way and understands the hazards of improper use.

WARNING: Liquids and other foods must not be heated in sealed containers since they are liable to explode. Microwave heating of beverages can result in delayed eruptive boiling, therefore care has to be taken when handling the container. Stir the liquid prior to and during heating/ reheating, let liquid stand for at least 20 seconds in the oven after cooking.

FIRE: If smoke is observed, switch off and unplug the appliance and keep the door closed in order to stifle any flames.

MAFF HEATING CATEGORY

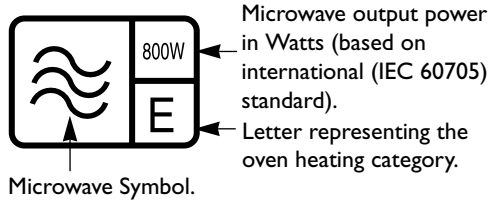

Microwave output power in Watts (based on international (IEC 60705) standard).

Letter representing the oven heating category.

The heating category (a letter A to E) developed by MAFF (Ministry of Agriculture, Fisheries and Food) with microwave oven and food manufacturers indicates the ability of the oven to heat small quantities of food (up to 500g [1lb 2oz]). It does not represent the general performance of the oven.

OVEN OUTPUT POWER	Less heating time required 600 700 800 900 1000 Watts More heating time required
	Less heating time required A B C D E More heating time required

Food packs carry cooking instructions for heating categories A to E. Follow instructions for the letter corresponding to the oven's heating category. The higher the output power and heating category of the oven the less heating time is required as shown opposite.

HOW YOUR OVEN WORKS

Microwaves are energy waves, similar to those used for TV and radio signals.

Electrical energy is converted into microwave energy, which is directed into the oven cavity via a waveguide. To prevent food and grease entering the wave guide it is protected by the waveguide cover.

Microwaves cannot pass through metal, because of this the oven cavity is made of metal and there is a fine metal mesh on the door. During cooking the microwaves bounce off the sides of the oven cavity at random.

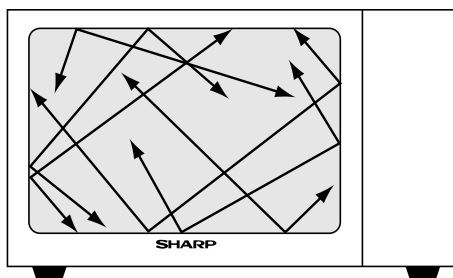

Microwaves will pass through certain materials, such as glass and plastic, to heat the food. (See "Suitable Cookware" on page 17).

Water, sugar and fat in food absorb microwaves which cause them to vibrate. This creates heat by friction, in the same way your hands get warm when you rub them together.

The outer areas of the food are heated by the microwave energy, then the heat moves to the centre by conduction, as it does in conventional cooking. It is important to turn, rearrange or stir food to ensure even heating.

Once cooking is complete, the oven automatically stops producing microwaves.

Standing time is necessary after cooking, as it enables the heat to disperse equally throughout the food.

MICROWAVE POWER LEVELS

Power Level	Press the POWER LEVEL button	Percentage
HIGH	x 1	100P
MEDIUM HIGH	x 2	70P
MEDIUM	x 3	50P
MEDIUM LOW (Defrost)	x 4	30P
LOW (Defrost)	x 5	10P

IMPORTANT: The microwave power level will default to 100P unless you press the **POWER LEVEL** button.

- For use of the power levels, please refer to the cooking charts and recipes on pages 21 - 32.

Generally the following recommendations apply:

100P - (HIGH output = 800W) used for fast cooking or reheating e.g. for casseroles, hot beverages, vegetables etc.

70P - (MEDIUM HIGH output = 560W) used for longer cooking of dense foods such as roast joints, meat loaf and plated meals, also for sensitive dishes such as sponge cakes. At this reduced setting, the food will cook evenly without over cooking at the sides.

- Your oven has 5 power levels, as shown.
- To change the power level for cooking, enter the required time and then press the **POWER LEVEL** button until the display indicates the desired level.

Power level

The microwave power level is varied by the microwave energy switching on and off. When using power levels other than 100P you will be able to hear the microwave energy pulsing on and off as the food cooks or defrosts.

Check the power level

To check the microwave power level during cooking, press the **POWER LEVEL** button. As long as your finger is pressing the **POWER LEVEL** button the power level will be displayed. The oven continues to count down although the display will show the power level.

50P - (MEDIUM output = 400W) for dense foods which require a long cooking time when cooked conventionally, eg. beef casserole, it is advisable to use this power setting to ensure the meat will be tender.

30P - (MEDIUM LOW output = 240W Defrost setting) to defrost, select this power setting, to ensure that the dish defrosts evenly. This setting is also ideal for simmering rice, pasta, dumplings and cooking egg custard.

10P - (LOW output = 80W) For gentle defrosting, eg. cream gateaux or pastry.

BEFORE OPERATION

Plug in the oven.

- The oven display will flash:
- Press the **STOP** button.
- The display will show:

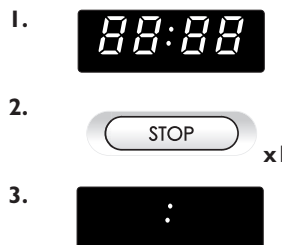

SETTING THE CLOCK

Your oven has a 12 hour and a 24 hour clock.

- To select the 12 hour clock, press and hold the **POWER LEVEL** button for 3 seconds. "12H" will appear on the display.

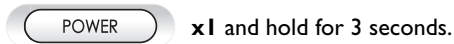

- To select the 24 hour clock, press and hold the **POWER LEVEL** button for 3 seconds, then press again. "24H" will appear on the display.

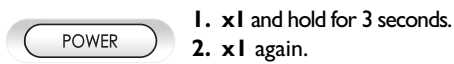

To set the time of day follow the instructions opposite.

NOTES:

- Press the **STOP** button if you make a mistake during programming.
- If the clock is set, when cooking is complete, the display will show the correct time of day. If the clock has not been set, the display will only show ":" when cooking is complete.
- If the electrical power supply to your microwave oven is interrupted, the display will intermittently show "88:88" after the power is reinstated. If this occurs during cooking, the programme will be erased. The time of day will also be erased.
- When you want to reset the time of day, follow the opposite example again.

1. Select the clock type required.



2. Enter the hours by turning the **TIME/WEIGHT/PORTION** knob.

⊙/KG/PCS



3. Press the **POWER LEVEL** button once.



x1



4. Enter the minutes by turning the **TIME/WEIGHT/PORTION** knob.

⊙/KG/PCS



5. To start the clock, press the **POWER LEVEL** button once.



x1

HOW TO OPERATE YOUR OVEN

Opening and closing the door:

To open the oven door, pull the door opening handle.

Starting the oven:

Close the door and press the **START/AUTO MINUTE** button.



Stopping the oven:

If you want to stop the oven during cooking, press the **STOP** button once or open the oven door.



If you want to cancel the cooking programme, press the **STOP** button twice.

Your oven enables you to cook and defrost food using the automatic programmes, or to cook and defrost food manually.

Automatic cooking and defrosting allows you to cook and defrost using preset programmes where the timings have been calculated for you, e.g **Express Cook** and **Express Defrost**.

Manual cooking and defrosting allows you to cook/defrost foods and weights which are not included in the automatic programmes.

The following are examples of manual cooking and defrosting.

For automatic cooking and defrosting refer to pages 11 - 13.

MANUAL COOKING

- Enter the cooking time and use microwave power levels 10P to 100P to cook (refer to page 7).
- Stir or turn the food, where possible, 2 - 3 times during cooking.
- After cooking, cover the food and leave to stand.
- Refer to the cooking charts in the cookbook section, pages 22 - 25.

Example:

To cook for 2 minutes 30 seconds on 70P microwave power.

1. Enter the cooking time by turning the **TIME/WEIGHT/PORTION** knob.

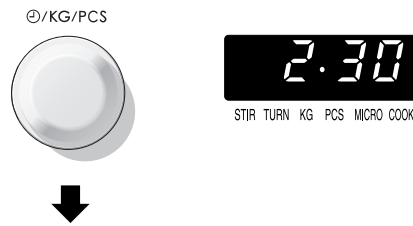

2. Input the power level by pressing the **POWER LEVEL** button twice.



3. Press the **START/AUTO MINUTE** button once to start cooking.



The display will count down through the set cooking time.

HOW TO OPERATE YOUR OVEN

MANUAL DEFROSTING

- Enter the defrosting time and use microwave power levels 10P or 30P to defrost (refer to page 7).
- Stir or turn the food, where possible, 2 - 3 times during defrosting.
- After defrosting, cover the food in foil and leave to stand until thoroughly defrosted.
- Refer to the defrosting charts in the cookbook section, page 21.

NOTES FOR MANUAL COOKING AND DEFROSTING:

- When the oven starts, the oven lamp will light and the turntable will rotate clockwise or anti-clockwise.
- Your oven can be programmed up to 90 minutes (90.00).
- If the door is opened during cooking/defrosting to stir or turn over food, the cooking time on the display stops automatically. The cooking/defrosting time starts to count down again when the door is closed and the **START/AUTO MINUTE** button is pressed.
- When cooking/defrosting is complete, the time of day will reappear on the display, if the clock has been set.
- If you want to know the power level during cooking, press the **POWER LEVEL** button. As long as your finger is touching the button, the power level will be displayed.

Example:

To defrost for 10 minutes on 30P microwave power.

1. Enter the defrosting time by turning the **TIME/WEIGHT/PORTION** knob.



2. Input the power level by pressing the **POWER LEVEL** button 4 times.



3. Press the **START/AUTO MINUTE** button once to start defrosting.



The display will count down through the defrosting time.

EXPRESS COOK / DEFROST

EXPRESS COOK enables you to cook 8 popular menus from frozen or chilled. Please refer to the chart on page 13.

EXPRESS DEFROST allows you to defrost 2 popular menus. Please refer to the chart on page 13.

Follow the examples below for details on how to operate these functions.

EXPRESS
COOK & DEFROST



EXPRESS COOK Example:

To cook roast beef from chilled weighing 1.0kg on EXPRESS COOK EC-2.

1. Select the menu required by pressing the **EXPRESS COOK/DEFROST** button twice.

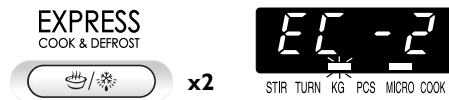

2. Enter the weight by turning the **TIME/WEIGHT/PORTION** knob until the desired weight is displayed.

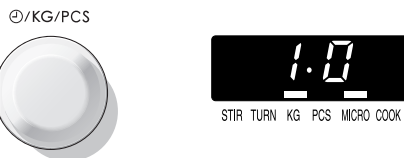

3. Press the **START/AUTO MINUTE** button once to start cooking.



The display will count down through the cooking time.

EXPRESS DEFROST Example:

To defrost a 0.2kg Steak.

1. Select the menu required by pressing the **EXPRESS COOK/DEFROST** button 9 times.



2. Enter the weight by turning the **TIME/WEIGHT/PORTION** knob until the desired weight is displayed.



3. Press the **START/AUTO MINUTE** button once to start defrosting.



The display will count down through the defrosting time.

EXPRESS COOK / DEFROST

NOTES:

Jacket potatoes: (EC-6) For this menu, the weight is input in pieces (i.e 1 piece = 1 potato = 250g). After selecting menu, use the **TIME/WEIGHT/PORTION** knob to select number of pieces from 1 - 4.

Cake: (EC-8) This menu has one setting for 800g. It is not necessary to enter the weight. When you select this menu, the display will show 0.8 kg automatically. See recipes on page 32 in the cookbook section.

Selecting Menu: The menu will be changed automatically by holding down the **EXPRESS COOK/DEFROST** button.

Weight Range: Food weight should be rounded up or down to the nearest 0.1 kg e.g. 0.65kg to 0.7kg or 0.34kg to 0.3kg. You are restricted to enter a weight within the range given (see chart on page 13). The weight is entered by holding down the **TIME/WEIGHT/PORTION** knob, as well as by pressing, until the desired weight appears. To cook or defrost food which is not included in the EXPRESS COOK/DEFROST chart, please refer to the charts in the cookbook section.

Defrost: If necessary, shield small areas of meat or poultry with flat pieces of aluminium foil. This will prevent thin areas becoming warm during defrosting. Ensure the foil does not touch the oven walls. Do not cook the meat or poultry until thoroughly defrosted.

Freezing Foods: Before freezing foods, ensure the food is fresh and of good quality.

- The final food temperature will vary according to the initial food temperature. Check food is thoroughly heated after cooking. If necessary, you can extend the cooking time manually.

EXPRESS COOK / DEFROST CHART

EXPRESS COOK CHART

No	MENU	WEIGHT RANGE	COOKING PROCEDURE
EC-1	Frozen Roast Beef / Lamb (-18°C)	0.5kg - 1.5kg	<ul style="list-style-type: none"> Place meat in a flan dish on the turntable. Turn meat over when the audible signal sounds.
EC-2	Chilled Roast Beef / Lamb (5°C)	0.5kg - 1.5kg	<ul style="list-style-type: none"> After cooking, leave meat to stand wrapped in aluminium foil for 10 minutes.
EC-3	Frozen Roast Poultry (-18°C)	1.2kg - 1.6kg	<ul style="list-style-type: none"> Pierce skin (chilled only) a few times and place poultry, breast side down, in a flan dish on the turntable.
EC-4	Chilled Roast Poultry (5°C)	1.2kg - 1.6kg	<ul style="list-style-type: none"> Turn poultry over when the audible signal sounds. When you cook frozen poultry with giblets, remove the giblets at first or second turn over. After cooking, leave poultry to stand wrapped in aluminium foil, for 10 minutes.
EC-5	Fresh Fish (fillets,steaks,whole)	0.2kg - 0.6kg	<ul style="list-style-type: none"> Arrange in a single layer in a large flan dish. Cover tightly with microwaveable cling film, pierce several times and place on the turntable. After cooking, leave to stand for 2-3 minutes before serving.
EC-6	Jacket Potatoes	1 - 4 pieces 250g each	<ul style="list-style-type: none"> Pierce each potato in several places, place towards the edge of the turntable. Turn potatoes over when the audible signal sounds. After cooking stand, wrapped in aluminium foil, for 5 minutes.
EC-7	Rice / Pasta	0.1kg - 0.3kg	<ul style="list-style-type: none"> Add 300ml (1/2 pint) boiling water per 100g (4oz) rice/ pasta. Do not cover. Stir when the audible signal sounds. Stand for 2 minutes before draining and rinsing in boiling water.
EC-8	Cake	0.8kg	<ul style="list-style-type: none"> Prepare the cake referring to the recipes on page 32. Place the prepared dish on the turntable. Stand for approx. 10 minutes after cooking. Remove from the cake dish.

EXPRESS DEFROST CHART

No	MENU	WEIGHT RANGE	COOKING PROCEDURE
Ed-1	Steak, Chops	0.2kg - 0.8kg	<ul style="list-style-type: none"> Place in a flan dish on the turntable. Turn over and rearrange when audible signal sounds. Stand, wrapped in foil, for 15-30 minutes until evenly defrosted.
Ed-2	Chicken Quarters	0.4kg - 1.2kg	<ul style="list-style-type: none"> Place quarters best side up in a flan dish on the turntable. Turn over and rearrange when audible signal sounds. Stand, wrapped in foil, for 15-30 minutes until evenly defrosted

For converting to Lb/oz please see conversion charts on page 20.

Weigh all meat and poultry prior to defrosting and cooking as the labelled weights are only approximate.

CONVENIENT FUNCTIONS

I. SEQUENCE COOKING

This function allows you to cook using up to 3 different stages.

Once programmed there is no need to interfere with the cooking operation as the oven will automatically move onto the next stage.

Example:

To cook for:

5 minutes on 70P microwave power (Stage 1)

16 minutes on 30P microwave power (Stage 2)

STAGE 1

1. Enter the cooking time by turning the **TIME/WEIGHT/PORTION** knob.



2. Input the power level by pressing the **POWER LEVEL** button twice.



STAGE 2

3. Enter the cooking time by turning the **TIME/WEIGHT/PORTION** knob.



4. Input the power level by pressing the **POWER LEVEL** button 4 times.



5. Press the **START/ AUTO MINUTE** button once to start cooking.



NOTE: If 100P is required on the final stage, it is not necessary to input the power level.

2. AUTO MINUTE

AUTO MINUTE enables you:

- To cook on 100P microwave power in multiples of 1 minute.
- To extend cooking time in multiples of 1 minute.

You can use this function for manual cooking only.

NOTE: The overall time can be extended to a maximum of 99 minutes.

Example: To cook for 2 minutes, press the **START/AUTO MINUTE** button twice.



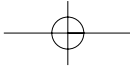

MICROWAVE COOKING ADVICE

Microwaves cook food faster than conventional cooking. It is therefore essential that certain techniques are followed to ensure good results.

Many of the following techniques are similar to those used in conventional cooking.

COOKING ADVICE NOTES:



- Always attend the oven when in use.
- Ensure that the utensils are suitable for use in a microwave oven. (See “Suitable Cookware” on page 17).
- Refer to the charts in the cookbook section for recommended cooking times and power levels.
- Do not place hot foods/utensils on a cold turntable or cold foods/utensils on a hot turntable.
- Liquids and foods must not be heated in sealed containers or jars/containers with lids on, as pressure will build up inside and may cause the container/jar to explode.
- Only use microwave popcorn within the recommended packaging (follow the manufacturers instructions). Never use oil unless specified by the manufacturer and never cook for longer than instructed.



WARNING:

Follow instructions in the SHARP operation manual at all times.
If you exceed recommended cooking times and use power levels that are too high, food may overheat, burn and in extreme circumstances, catch fire and damage the oven.

Cooking Techniques

Arrange	<p>Place the thickest parts of food towards the outside of the dish. e.g. Chicken drumsticks.</p> <p>Foods that are placed towards the outside of the dish will receive more energy, so cook quicker, than those in the centre.</p> 
Cover	<p>Certain foods benefit from being covered during microwave cooking, follow recommendations where given.</p> <p>Use vented microwave cling film or a suitable lid.</p>
Pierce	<p>Foods with a shell, skin or membrane must be pierced in several places before cooking or reheating as steam will build up and may cause food to explode.</p> <p>e.g. Potatoes, Fish, Chicken, Sausages.</p> 
Stir, turn and rearrange	<p>NOTE: Eggs in their shells and hard / soft boiled eggs should not be heated in the microwave oven as they may explode, even after cooking has ended.</p>
Stand	<p>For even cooking it is essential to stir, turn and rearrange food during cooking. Always stir and rearrange from the outside towards the centre.</p> <p>Standing time is necessary after cooking as it enables the heat to disperse equally throughout the food.</p>

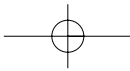

MICROWAVE COOKING ADVICE

Food Characteristics	
Composition	Foods high in fat or sugar (e.g. Christmas pudding, mince pies) require less heating time. Care should be taken as overheating can lead to fire. Bones in food conduct heat, making the food cook more quickly. Care must be taken so that the food is cooked evenly.
Density	Food density will affect the amount of cooking time needed. Light, porous foods, such as cakes or bread, cook more quickly than heavy, dense foods, such as roasts and casseroles.
Quantity	The number of microwaves in your oven remains the same regardless of how much food is being cooked. The cooking time must be increased as the amount of food placed in the oven increases. e.g. Four potatoes will take longer to cook than two.
Size	Small foods and small pieces cook faster than large ones, as microwaves can penetrate from all sides to the centre. For even cooking make all the pieces the same size.
Shape	Foods which are irregular in shape, such as chicken breasts or drumsticks, take longer to cook in the thicker parts. For even cooking, place the thickest parts to the outside of the dish where they will receive more energy. Round shapes cook more evenly than square shapes when microwave cooking.
Temperature of food	The initial temperature of food affects the amount of cooking time needed. Chilled foods will take longer to cook than food at room temperature. e.g. A cake made with chilled ingredients, (i.e. margarine) will take longer to cook than a cake made with ingredients at room temperature. The temperature of the container is not a true indication of the temperature of the food or drink. Cut into foods with fillings, for example jam doughnuts, to release heat or steam.



Face & Hands: Always use oven gloves to remove food or cookware from the oven. Stand back when opening the oven door to allow heat or steam to disperse. When removing covers (such as cling film), opening roasting bags or popcorn packaging, direct steam away from face and hands.



Check the temperature of food and drink and stir before serving. Take special care when serving to babies, children or the elderly. The contents of feeding bottles and baby food jars are to be stirred or shaken and the temperature is to be checked before consumption to avoid burns.

SUITABLE COOKWARE

To cook/defrost food in a microwave oven, the microwave energy must be able to pass through the container to penetrate the food. Therefore it is important to choose suitable cookware.

Round/oval dishes are preferable to square/oblong ones, as the food in the corners tends to overcook. A variety of cookware can be used as listed below.

Cookware	Microwave Safe	Comments
Aluminium foil Foil Containers	✓ / X	Small pieces of aluminium foil can be used to shield food from overheating. Keep foil at least 2cm from the oven walls, as arcing may occur. Foil containers are not recommended unless specified by the manufacturer, e.g. Microfoil ®, follow instructions carefully.
Browning dishes	✓	Always follow the manufacturers instructions. Do not exceed heating times given. Be very careful as these dishes become very hot.
China and ceramics	✓ / X	Porcelain, pottery, glazed earthenware and bone china are usually suitable, except for those with metallic decoration.
Glassware e.g. Pyrex ®	✓	Care should be taken if using fine glassware as it can break or crack if heated suddenly.
Metal	X	It is not recommended to use metal cookware as it will arc, which can lead to fire.
Plastic/Polystyrene e.g fast food containers	✓	Care must be taken as some containers warp, melt or discolour at high temperatures.
Cling film	✓	It should not touch the food and must be pierced to let the steam escape.
Freezer/Roasting bags	✓	Must be pierced to let steam escape. Ensure bags are suitable for microwave use. Do not use plastic or metal ties, as they may melt or catch fire due to the metal 'arcing'.
Paper - Plates, cups and kitchen paper	✓	Only use for warming or to absorb moisture. Care must be taken as overheating may cause fire.
Straw and wooden containers	✓	Always attend the oven when using these materials as overheating may cause fire.
Recycled paper and newspaper	X	May contain extracts of metal which will cause 'arcing' and may lead to fire.

NOTE: When heating food in plastic or paper containers, monitor the oven due to the possibility of ignition.

DEFROSTING ADVICE

Defrosting food using your microwave oven is the quickest method of all.

It is a simple process but the following instructions are essential to ensure the food is thoroughly defrosted.

Rearrange	<p>Foods that are placed towards the outside of the dish will defrost quicker than foods in the centre. It is therefore essential that the food is rearranged up to 4 times during defrosting.</p> <p>Move closely packed pieces from the outside to the centre and rearrange over-lapping areas.</p> <p>This will ensure that all parts of the food defrosts evenly.</p>
Separate	<p>Foods may be stuck together when removed from the freezer. It is important to separate foods as soon as it is possible during defrosting.</p> <p>e.g. bacon rashers, chicken fillets.</p>
Shield	<p>Some areas of food being defrosted may become warm. To prevent them becoming warmer and starting to cook, these areas can be shielded with small pieces of foil, which reflect microwaves. e.g. legs and wings on a chicken.</p>
Stand	<p>Standing time is necessary to ensure food is thoroughly defrosted.</p> <p>Defrosting is not complete once the food is removed from the microwave oven. Food must stand, covered, for a length of time to ensure the centre has completely defrosted.</p>
Turn over	<p>It is essential that all foods are turned over at least 3 - 4 times during defrosting. This is important to ensure thorough defrosting.</p>

NOTES:

- Remove all packaging and wrapping before defrosting.
- To defrost food, use microwave power levels MEDIUM LOW or LOW.
- Please refer to the defrosting chart on page 21 for further information.

REHEATING ADVICE

For the reheating of foods, follow the advice and guidelines below to ensure food is thoroughly reheated before serving.

Plated meals	<p>Remove any poultry or meat portions, reheat these separately, see below.</p> <p>Place smaller items of food to the centre of the plate, larger and thicker foods to the edge. Cover with vented microwave cling film and reheat on MEDIUM, stir/ rearrange halfway through reheating.</p> <p>NOTE: Ensure the food is thoroughly reheated before serving.</p>	
Sliced meat	<p>Cover with vented microwave cling film and reheat on MEDIUM. Rearrange at least once to ensure even reheating.</p> <p>NOTE: Ensure the meat is thoroughly reheated before serving.</p>	
Poultry portions	<p>Place thickest parts of the portions to the outside of the dish, cover with vented microwave cling film and reheat on MEDIUM HIGH. Turn over halfway through reheating.</p> <p>NOTE: Ensure the poultry is thoroughly reheated before serving.</p>	
Casseroles	<p>Cover with vented microwave cling film or a suitable lid and reheat on MEDIUM.</p> <p>Stir frequently to ensure even reheating.</p> <p>NOTE: Ensure the food is thoroughly reheated before serving.</p>	

To achieve the best results when reheating, select a suitable microwave power level appropriate to the type of food. e.g. A bowl of vegetables can be reheated using HIGH, while a lasagne which contains ingredients that cannot be stirred, should be reheated using MEDIUM.

NOTES:

- Remove food from foil or metal containers before reheating.
- Reheating times will be affected by the shape, depth, quantity and temperature of food together with the size, shape and material of the container.



Never heat liquids in narrow-necked containers, as this could result in the contents erupting from the container and may cause burns.

- To avoid overheating and fire, special care must be taken when reheating foods with a high sugar or fat content, e.g. mince pies or Christmas pudding.
- Never heat oil or fat for deep frying as this may lead to overheating and fire.
- Canned potatoes should not be heated in the microwave oven, follow the manufacturer's instructions on the can.



The contents of feeding bottles and baby food jars are to be stirred or shaken and the temperature is to be checked before consumption to avoid burns.

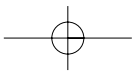

COOKBOOK

CONTENTS

INTRODUCTION, COOKERY NOTES & CONVERSION CHARTS20

DEFROSTING CHART:

 Meat, poultry, fish, fruit, bread, pastry, savoury pie & quiche21

COOKING CHARTS:

 Meat, poultry & fish22

 Fresh & frozen vegetables & fruit23

 Rice, pasta & eggs24

REHEATING CHART25

RECIPES25-32

INTRODUCTION

This Cookbook contains a wide variety of recipes developed specifically for your microwave oven. These will give you successful results and will save time and electricity. The recipes demonstrate the capabilities of your oven and prove that microwave technology is the efficient and effective alternative to conventional cooking.

The cookery notes below compliment all cooking procedures in this cookbook and should be read in advance of recipe preparation.

COOKERY NOTES

- Please weigh all meat and poultry prior to defrosting and cooking, as labelled weights are only approximate.
- Where dishes are covered use vented microwave cling film unless otherwise stated. Where dishes are lined, use greaseproof paper unless otherwise stated.
- Please note that all serving quantities are approximate.
- Cooking times in the charts and recipes are based on standard conditions. Cooking results will vary according to the condition of foods, utensils and the oven. Please check the cooking result and, if necessary, adjust cooking times accordingly.
- Serve all dishes immediately unless otherwise stated.
- Half-fat, skimmed or full-fat milk may be used in all recipes, as preferred.
- Where it is necessary to blend foods, use a food processor, liquidiser or press through a sieve.
- The recipes in this cookery book were developed using chilled eggs and fat. Room temperature ingredients may give a different result.
- Chilled foods are to be cooked from 5°C. **DO NOT COOK FROM FROZEN.**
- Ambient/fresh/dried/canned foods are to be cooked from 20°C. **DO NOT COOK FROM FROZEN.**
- Frozen foods are to be cooked from -18°C.

CONVERSION CHARTS

WEIGHT MEASURES		VOLUME MEASURES		SPOON MEASURES	
15g	1/2oz	30ml	1floz	1.25ml	1/4 teaspoon
25g	1oz	100ml	3floz	2.5ml	1/2 teaspoon
50g	2oz	150ml	5floz (1/4 pint)	5ml	1 teaspoon
100g	4oz	300ml	10floz (1/2 pint)	15ml	1 tablespoon
175g	6oz	600ml	20floz (1 pint)		
225g	8oz				
450g	1lb				

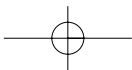

DEFROSTING CHART

FOOD	DEFROST TIME	MICRO POWER LEVEL	▼ METHOD	● STANDING TIME
Meat Joints (Beef, Lamb, Pork)	16 - 17 Minutes/ 450g	10P	Place in a flan dish. Turn over 4-5 times during defrosting. Shield.	90 - 120 Minutes
Minced Meat	10 - 12 Minutes/ 450g	Stage 1: 30P Stage 2: 10P	Place on a plate. Use sequence programming. Stage 1: Defrost on 30P for the first quarter of cooking time. Stage 2: Defrost on 10P for the remaining cooking time. Turn over 3-4 times, removing defrosted mince each time.	15 - 30 Minutes
Steak/Chops 2cm (3/4") thick	14 - 15 Minutes/ 450g	10P	Place in a flan dish. Turn 2-3 times, separate during defrosting. Shield.	25 - 30 Minutes
Sausages	6 - 7 Minutes/ 450g	30P	Place in a flan dish. Turn 2-3 times, separate during defrosting. Shield.	15 - 20 Minutes
Bacon	10 - 12 Minutes/ 450g	10P	Place on a plate. Separate and re-arrange twice during defrosting. Shield.	5 - 10 Minutes
Beefburgers	12 - 13 Minutes/ 450g	10P	Place on a plate. Turn over and separate twice during defrosting.	15 - 20 Minutes
❖ Whole Poultry (Chicken, Turkey, Duck)	19 - 20 Minutes/ 450g	10P	Place in a flan dish. Turn 4-5 times, during defrosting. Shield.	60 - 90 Minutes
Chicken Legs	8 - 9 Minutes/ 450g	30P	Place in a flan dish. Turn 2-3 times, separate during defrosting. Shield.	25 - 30 Minutes
Chicken/Turkey Breasts & Fillets	10 - 11 Minutes/ 450g	30P	Place in a flan dish. Turn 2-3 times, separate during defrosting. Shield.	15 - 30 Minutes
Minced Turkey	7 - 8 Minutes/ 450g	30P	Place in a bowl. Turn 3-4 times, removing defrosted mince each time.	15 - 20 Minutes
Fish (Whole/Fillets/Steaks)	8 - 9 Minutes/ 450g	30P	Place in a flan dish. Separate and re-arrange twice during defrosting. Shield.	15 Minutes
Apples/Rhubarb	7 - 8 Minutes/ 450g	30P	Place in a dish. Stir during defrosting. Shield.	15 - 20 Minutes
Bread (sliced)	5 Minutes/ 400g	30P	Place on the turntable. Separate and rearrange during defrosting.	5 - 10 Minutes
Pastry (Puff or Shortcrust)	6 - 7 Minutes/ 450g	10P	Place on a plate. Turn over half way through defrosting.	10 - 15 Minutes
Savoury Pie & Quiche (cooked)	15 - 16 Minutes/ 500g pie, quiche 20 - 21 Minutes/ 800g pie, quiche	10P	Remove from foil container. Place in a flan dish.	20 - 30 Minutes
Fruit Pie	11 - 12 Minutes/ 400g pie 16 - 17 Minutes/ 700g pie	10P 10P	Remove from foil container. Place in a flan dish.	20 - 30 Minutes

- ▼ Method: If shielding is necessary, use small pieces of foil.
❖ Poultry: Chicken, turkey and duck must be defrosted without giblets.
● Standing Time: During recommended standing time, wrap or cover food in foil.

COOKING CHART

FOOD	COOKING TIME	MICRO POWER LEVEL	▼ METHOD	● STANDING TIME
Beefburgers	10 - 11 Minutes/ 450g	70P	Place in a flan dish. Turn over halfway through cooking.	2 - 3 Minutes
Minced Meat	8 Minutes/ 450g	70P	Place in a bowl. Stir 2-3 times during cooking.	2 - 3 Minutes
Sausages (thick)	8 - 9 Minutes/ 8 sausages	70P	Place in a flan dish. Turn over halfway through cooking.	2 Minutes
Sausages (thin)	6 - 7 Minutes 8 sausages	70P	Place in a flan dish. Turn over halfway through cooking.	2 Minutes
Bacon	3 - 4 Minutes/ 2 - 4 slices	100P	Place in a flan dish. Turn over halfway through cooking.	1 Minute
Whole Poultry: Chicken, Turkey & Duck	12 - 13 Minutes/ 450g	70P	Place in a flan dish. Turn over halfway through cooking.	10 Minutes
Chicken/Turkey Portions, Breasts & Drumsticks	11 - 12 Minutes/ 450g	70P	Place in a flan dish. Turn over halfway through cooking.	5 Minutes
Minced Turkey	9 - 10 Minutes/ 450g	100P	Place in a bowl. Stir 3-4 times during cooking.	2 - 3 Minutes
Fish Fillets	9 - 10 Minutes/ 450g	70P	Place in a flan dish. Cover with cling film.	2 - 3 Minutes
Whole fish & Steaks (Trout, Mackerel)	7 - 8 Minutes/ 450g	70P	Place in a flan dish. Cover with cling film.	3 - 4 Minutes

- ▼ Method: If shielding is necessary, use small, pieces of foil.
- Standing Time: During recommended standing time, wrap or cover food in foil.
Note: Prior to cooking, food is refrigerated, 5°C.

COOKING CHART

FOOD	COOKING TIME	MICRO POWER LEVEL	▼ METHOD	● STANDING TIME
Aubergines & Broccoli (fresh)	6 Minutes/ 225g	100P	Place in dish. Add 30ml (2 tbsp) water. Cover dish. Stir halfway through cooking.	2 Minutes
Sliced Beans (green - fresh)	6 Minutes/ 225g	100P	Place in dish. Add 30ml (2 tbsp) water. Cover dish. Stir halfway through cooking.	2 Minutes
Brussels Sprouts (fresh)	6 Minutes/ 225g	100P	Place in dish. Add 45ml (3 tbsp) water. Cover. Stir halfway through cooking.	2 Minutes
Cabbage, Carrots, Cauliflower, Celery	6 Minutes/ 225g	100P	Slice or break into florets. Place in dish. Add 30ml (2 tbsp) water. Cover. Stir halfway through cooking.	2 Minutes
Corn on the Cob (fresh)	7 Minutes/ 225g	100P	Place in dish. Add 45ml (3 tbsp) water. Cover. Stir 1/2 through cooking.	2 Minutes
Sliced Courgettes & Leeks (fresh)	5 Minutes/ 225g	100P	Place in dish. Add 30ml (2 tbsp) water. Cover dish. Stir halfway through cooking.	2 Minutes
Sliced Parsnips & Spinach (fresh)	6 Minutes/ 225g	100P	Place in dish. Add 45ml (3 tbsp) water. Cover. Stir halfway through cooking.	2 Minutes
Peas (fresh)	5 Minutes/ 225g	100P	Place in dish. Add 30ml (2 tbsp) water. Cover dish. Stir halfway through cooking.	2 Minutes
Potatoes, Jacket (250g - each)	12 Minutes/ 2 potatoes	100P	Prick in several places. Place in dish. Place on the edge of the turntable.	5 Minutes
Potatoes, Boiled (old & new - fresh)	11 Minutes/ 225g	100P	Cut into quarters. Place in dish. Add 60ml (4 tbsp) water. Cover. Stir halfway through cooking.	4 Minutes
Diced Swede & Turnips (fresh)	8 Minutes/ 225g	100P	Place in dish. Add 45ml (3 tbsp) water. Cover dish. Stir halfway through cooking.	2 Minutes
Beans & Cabbage (green - frozen)	6 Minutes/ 225g	100P	Place in dish. Add 15ml (1 tbsp) water. Cover dish. Stir halfway through cooking.	2 Minutes
Broccoli, Leaf Spinach /Brussels Sprouts (frozen)	7 Minutes/ 225g	100P	Place in dish. Add 15ml (1 tbsp) water. Cover dish. Stir halfway through cooking.	2 Minutes
Carrots - sliced (frozen)	7 Minutes/ 225g	100P	Place in dish. Add 15ml (1 tbsp) water. Cover dish. Stir halfway through cooking.	3 Minutes
Cauliflower florets (frozen)	6 Minutes/ 225g	100P	Place in dish. Add 15ml (1 tbsp) water. Cover dish. Stir halfway through cooking.	2 Minutes
Corn on the Cob (frozen)	12 Minutes/ 2 cobs	100P	Place in dish. Cover dish. Turnover halfway through cooking.	3 Minutes
Peas, Sweetcorn & Mixed Vegetables (frozen)	6 Minutes/ 225g	100P	Place in dish. Cover dish. Stir halfway through cooking.	2 Minutes
Apples & Rhubarb	6 Minutes/ 450g	100P	Peel & slice. Place in a dish and cover. Stir during cooking.	2 Minutes
Blackberries/Raspberries/Redcurrants	6 Minutes/ 450g	100P	Place in a dish and cover. Stir during cooking.	2 Minutes

NOTE:

- Fresh vegetables and fruit are cooked from 20°C (ambient temperature).
- Frozen vegetables are cooked from -18°C.

COOKING CHART

FOOD	* COOKING TIME	MICRO POWER LEVEL	▼ METHOD	● STANDING TIME
White rice (long grain)	14 - 15 Minutes	70P	Add 300ml (1/2 pint) boiling water/100g rice. Do not cover. Stir twice during cooking.	2 Minutes
Brown rice	20 - 21 Minutes	70P	Add 400ml (14fl.oz) boiling water/100g rice. Do not cover. Stir twice during cooking.	2 Minutes
DRIED PASTA				
Spaghetti (short cut)	11 - 12 Minutes	70P	Add 300ml (1/2 pint) boiling water/100g pasta. Do not cover. Stir twice during cooking.	2 Minutes
Macaroni (short cut)	12 - 13 Minutes	70P	Add 300ml (1/2 pint) boiling water/100g pasta. Do not cover. Stir twice during cooking.	2 Minutes
Tagliatelle	10 - 11 Minutes	70P	Add 300ml (1/2 pint) boiling water/100g pasta. Do not cover. Stir twice during cooking.	2 Minutes
Pasta shells	11 - 12 Minutes	70P	Add 300ml (1/2 pint) boiling water/100g pasta. Do not cover. Stir twice during cooking.	2 Minutes
FRESH PASTA				
Spaghetti/ Tagliatelle	4 - 5 Minutes	70P	Add 300ml (1/2 pint) boiling water/100g pasta. Do not cover. Stir twice during cooking.	2 Minutes
Fusilli/Penne/ Conchiglie/ Farfalle	4 - 5 Minutes	70P	Add 300ml (1/2 pint) boiling water/100g pasta. Do not cover. Stir twice during cooking.	2 Minutes
Ravioli	6 - 7 Minutes	70P	Add 300ml (1/2 pint) boiling water/100g pasta. Do not cover. Stir twice during cooking.	2 Minutes
Tortellini (white)	7 - 8 Minutes	70P	Add 300ml (1/2 pint) boiling water/100g pasta. Do not cover. Stir twice during cooking.	2 Minutes
Tortellini (brown)	8 - 9 Minutes	70P	Add 300ml (1/2 pint) boiling water/100g pasta. Do not cover. Stir twice during cooking.	2 Minutes
EGGS				
Omelette	INGREDIENTS 15g butter 4 eggs (medium) 90ml (6tbsp) milk salt & pepper	70P	1 Whisk together eggs and milk. Season. 2 Place butter in a 20.4cm flan dish. Heat on 100P for 30 seconds, until melted. Coat the dish with the melted butter. 3 Pour omelette mixture into flan dish. Cook on 70P for 3 minutes. Whisk mixture and cook again on 70P for 5 minutes.	30 Seconds
Scrambled	15g butter 2 eggs (medium) 30ml (2tbsp) milk salt & pepper	70P	1 Melt the butter in a bowl on 70P for 30 seconds 2 Add the eggs, milk and seasoning and mix well. 3 Cook on 70P for 4 minutes, stirring every minute.	30 Seconds

* Cooking Time: Cooking time is constant for any quantity of rice or pasta, quantity of boiling water has to be adjusted according to quantity of rice or pasta, see Method.

● Standing Time (rice & pasta only): After standing, rinse in boiling water prior to serving.

REHEATING CHART

FOOD	COOKING TIME	MICRO POWER LEVEL	METHOD	STANDING TIME
Canned foods (Soup, Baked beans, Spaghetti, Vegetables)	6 - 7 Minutes/ 425g can	70P	Remove from can. Place in a dish and cover. Stir halfway through cooking.	2 Minutes
Bread rolls/ Croissants	40 - 50 Seconds/ 2 croissants/2 rolls	70P	Place on kitchen roll.	Nil
Christmas pudding	40 Seconds/125g slice 1 Minute/175g pudding	70P	Place in a flan dish. Do not exceed cooking time advised by food manufacturer.	30 Seconds
Sausage rolls (cooked, chilled approx. 50g each)	2 Minutes/2 sausage rolls 3 Minutes/4 sausage rolls 4 Minutes/6 sausage rolls	70P	Place in a flan dish. Do not exceed cooking time advised by food manufacturer.	30 Seconds
Quiche, (cooked, chilled)	4 - 5 Minutes/175g 7 - 8 Minutes/400g 10 - 11 Minutes/700g	70P	Place directly on the turntable or in a flan dish.	1 - 2 Minutes 2 - 3 Minutes
Meat pie (cooked, chilled)	4 - 5 Minutes/150g 8 - 9 Minutes/500g 12 - 13 Minutes/800g	70P	Remove from foil container and place in flan dish or on plate.	2 - 3 Minutes 3 - 4 Minutes
Fruit pie (cooked, chilled)	30 - 40 Seconds/50g - 70g 5 - 6 Minutes/450g 8 - 9 Minutes/700g	50P	Remove from foil container and place in flan dish or on plate.	1 Minute 1 - 2 Minutes 2 - 3 Minutes

NOTE: Take care when heating foods with high sugar or fat content, for example, Christmas pudding and mince pies. DO NOT EXCEED THE REHEATING TIMES GIVEN IN THE CHART ABOVE.

RECIPES

AVOCADO AU GRATIN

Serves 2 - 4

75g fresh breadcrumbs
50g cooked ham, finely chopped
142ml double cream
salt and pepper to taste
5ml (1 tsp) fresh parsley, chopped
2 large ripe avocados
15ml (1 tbsp) lemon juice
50g cheese, grated
fresh parsley sprigs to garnish

- 1 Place the breadcrumbs and ham in a bowl. Add enough cream to bind the mixture. Season with salt and pepper to taste and stir in the parsley. Cook on 100P for 3 minutes.
- 2 Cut the avocados in half. Remove the stone and brush the flesh with lemon juice. Fill each avocado half with the breadcrumb mixture.
- 3 Place the filled avocados in a flan dish and sprinkle with the grated cheese.
- 4 Cook on 100P for 4 minutes, until the cheese has melted. Garnish with sprigs of fresh parsley.

RECIPES

VEGETABLE & BEAN SOUP

Serves 4-6

75g celery, sliced
 125g carrots, chopped
 2 cloves garlic, crushed
 100g leeks, sliced
 125g black eyed beans, cooked
 125g chick peas, chopped
 125g kidney beans, cooked
 100g sweetcorn, canned
 400g chopped tomatoes, canned
 600ml (1 pint) hot vegetable stock
 salt and pepper to taste

- 1 Place the celery, carrots, garlic and leeks in a 2.5 litre (approx. 4 pints) bowl and cook on 100P for 3 minutes.
- 2 Place the remaining ingredients into the bowl and mix well.
- 3 Cook on 50P for 40 minutes, stirring 3-4 times during cooking.

STUFFED PEPPERS

Serves 2-4

4 large green, red or yellow peppers
 225g minced pork
 200g cooked rice
 75g red pepper, finely chopped
 75g spring onions
 15ml (1 tbsp) garlic purée
 5ml (1 tsp) ground cumin
 salt and pepper
 1 egg (medium)
 100g cheddar cheese, grated

- 1 Cut the top off the peppers. Remove seeds and membranes. Place in a greased 25cm (10") flan dish.
- 2 In a medium bowl, combine all remaining ingredients except cheese. Fill each pepper with equal amounts of the mixture.
- 3 Sprinkle the cheese over the filling.
- 4 Place dish on the turntable and cook on 70P for 18 minutes.

FISH PIE

Serves 4

900g potatoes, peeled and chopped
 135ml (9 tbsp) water
 25g margarine
 30 - 60ml (2 - 4 tbsp) milk
 salt and pepper to taste
 600g fish fillets (e.g. fresh cod)
 300ml (1/2 pint) white sauce (See Page 31)
 10ml (2 tsp) dried dill

- 1 Place potatoes in a bowl, add the water. Cover and cook on 100P for 20 minutes, until soft enough to mash. Mash with margarine, milk and seasoning.
- 2 Place fish in a flan dish in a single layer, cover and cook on 70P for 14 minutes. Flake the fish and mix into the sauce. Add the dill and mix well.
- 3 Pour into a casserole dish. Spread the potatoes on top.
- 4 Cook on 70P for 20 minutes.

INDONESIAN SALMON

Serves 4

20ml (4 tsp) indonesian curry paste
 20ml (4 tsp) sweet chilli sauce
 5ml (1 tsp) garlic purée
 5ml (1 tsp) english mustard powder
 30ml (2 tbsp) plain flour
 284ml soured cream
 4 salmon fillets (approx. 225g each)

- 1 Mix all the ingredients together in a bowl, except the cream and salmon.
- 2 Place a quarter of this mixture into another bowl, cut a slit into each fillet lengthways and then place equal amounts of the mixture into each slit.
- 3 Place the fillets into a flan dish and cook on 70P for 14 minutes.
- 4 Stir the cream into the remaining mixture to make the sauce, keep refrigerated until required.

RECIPES

TUNA STUFFED AUBERGINES

Serves 4

2 medium aubergines
salt
25g margarine
150g onion, chopped
50g mushroom, chopped
15ml (1 tbsp) tomato purée
15ml (1 tbsp) garlic purée
200g canned tuna, drained
100g canned sweetcorn
50g cheddar cheese, grated

- 1 Cut the aubergines in half lengthways and score the flesh with a knife. Sprinkle with salt and leave for 30 minutes. Rinse well.
- 2 Place the eggplant halves, cut side down, in a 25.4cm flan dish. Cover and cook on 70P for 8 minutes until soft.
- 3 Place the margarine, onion and mushroom in a bowl and cook on 100P for 3 minutes until soft.
- 4 Add the tomato purée, garlic purée, tuna and sweetcorn.
- 5 Scoop out the flesh from the aubergines and finely chop. Add to tuna mixture and mix well.
- 6 Pile the mixture into each aubergines half and sprinkle with cheese.
- 7 Place in a flan dish and cook on 70P for 12 minutes.

FISH RISOTTO

Serves 4

75g onion, chopped
75g celery, sliced
75g green pepper, seeded and sliced
75g red pepper, seeded and sliced
300g fish fillet, chunks
250g uncooked prawns
1.25ml (1/4 tsp) cayenne pepper
2.5ml (1/2 tsp) ground cumin
75g canned sweetcorn, drained
200g white long grain rice
750ml (1 1/4 pint) hot fish stock
salt and pepper to taste

- 1 Place all ingredients into a 2.5 litre (approx. 4 pint) casserole dish and mix well.
- 2 Place on the turntable. Do not cover.
- 3 Cook on 70P for 35 minutes, stir 2-3 times during cooking.

BEEF CASSEROLE

Serves 4

45ml (3 tbsp) plain flour
salt and pepper
500g braising steak, diced
450ml (3/4 pint) hot beef stock
150ml (1/4 pint) red wine
30ml (2 tbsp) tomato purée
30ml (2 tbsp) worcestershire sauce
salt and pepper to taste
30ml (2 tbsp) cornflour blended with water
200g carrots, sliced
100g onions, sliced
400g potatoes, par-boiled and cubed

- 1 Mix together the flour, salt and pepper, then toss the steak in the seasoned flour until well coated.
- 2 Pour the beef stock, wine, tomato puree, worcestershire sauce, seasoning and blended cornflour into a 2.5 litre (4 pint) casserole dish and stir well.
- 3 Stir in the steak, carrots, onions and potatoes.
4. Cook using sequence programming on 50P for 35 minutes then 70P for 20 minutes. Leave to stand for 5 minutes before serving, so that the meat relaxes to improve texture.

RECIPES

BEEF RISOTTO

Serves 4

75g onion, chopped
 75g celery, sliced
 75g green pepper, seeded and sliced
 75g red pepper, seeded and sliced
 300g beef fillet, thinly sliced into 5cm strips
 1.25ml (1/4 tsp) cayenne pepper
 2.5ml (1/2 tsp) ground cumin
 75g canned sweetcorn, drained
 200g white long grain rice
 750ml (1 1/4 pint) hot beef stock
 salt and pepper to taste

- 1 Place all ingredients into a 2.5 litre (approx. 4 pint) casserole dish and mix well.
- 2 Place on the turntable. Do not cover.
- 3 Cook on 70P for 35 minutes, stir 2-3 times during cooking.

TOMATO, PASTA LAYER

Serves 4

800g canned, chopped tomatoes in tomato sauce
 150g red pesto
 15ml (1 tbsp) garlic puree
 150g mushrooms, sliced
 100g sun-dried tomatoes, drained and chopped
 salt and pepper
 500g fresh meat filled ravioli
 300ml (1/2 pint) cheese sauce

- 1 Empty the tomatoes, pesto, garlic, mushrooms and seasoning into a large bowl and cook on 100P for 12 minutes.
- 2 Spread half the tomato mixture over the base of a 25cm (10") round 5cm (2") deep glass dish.
- 3 Place a single layer using half the pasta on top of the sauce.
- 4 Repeat the process again using the remaining sauce and pasta.
- 5 Cover the pasta with the cheese sauce.
- 6 Place on the turntable and cook on 50P for 35 minutes.

BOLOGNESE SAUCE

Serves 4

30ml (2 tbsp) vegetable oil
 150g onion, finely chopped
 100g mushrooms, chopped
 2 cloves garlic, crushed
 1 bay leaf
 400g canned, chopped tomatoes
 30ml (2 tbsp) tomato purée
 450g lean minced beef
 150ml (1/4 pint) red wine
 150ml (1/4 pint) hot beef stock
 salt and pepper to taste
 30ml (2 tbsp) cornflour blended with 30ml water

- 1 Place oil, onion, mushrooms and garlic into a 2.5 litre (approx. 4 pint) dish and mix well.
- 2 Cook on 70P for 4 minutes.
- 3 Add all the remaining ingredients, mix thoroughly.
- 4 Cook on 70P for 25 minutes, until sauce is thick. Stir 2-3 times during cooking. Serve hot with spaghetti.

Bolognese Sauce- Variations:

Chilli Con Carne: Make as the bolognese sauce. At stage 3, add 450g drained canned red kidney beans and 5 - 15ml (1 - 3 tsp) chilli powder, to taste.

RECIPES

CREAMY TURKEY CASSEROLE

Serves 4

25g margarine
600g turkey, cubed
200g button mushrooms, sliced
300g leeks, sliced
salt and pepper

Sauce:

50g margarine
50g plain flour
5ml (1 tsp) cayenne pepper
30ml (2 tbsp) english mustard powder
100g creamed coconut
300ml (1/2 pint) milk
salt and pepper
250g mascarpone cheese

- 1 Place the margarine, turkey, mushrooms, leeks, salt and pepper into a 2.5 litre (approx. 4 pint) casserole dish and cook on 100P for 10 minutes.
- 2 To make sauce, place margarine in a bowl and heat on 100P for 30 seconds until melted.
- 3 Stir in the flour, cayenne pepper, mustard powder and creamed coconut.
- 4 Whisk in the milk and cook on 100P for 5 minutes, stir every 2 minutes until thick and smooth. Season with salt and pepper.
- 5 Mix the mascarpone cheese into the sauce and drain the juice from the turkey into the sauce.
- 6 Pour the sauce over the turkey mixture. Mix well. Place on the turntable and cook on 70P for 25 minutes, stir 1-2 times during cooking.

HONEYED CHICKEN

Serves 4

4 boneless chicken breasts (approx. 200g each)
75ml (5 tbsp) clear honey
30ml (2 tbsp) honey mustard
2.5 ml (1/2 tsp) dried tarragon
30ml (2 tbsp) tomato purée
150ml (1/4 pint) chicken stock
15ml (1 tbsp) cornflour blended with water
salt and pepper to taste

- 1 Place the chicken breasts in a casserole dish.
- 2 Mix all remaining ingredients together and pour over the chicken.
- 3 Cook on 70P for 30 minutes. Turnover and coat the chicken with the sauce 3-4 times during cooking.

CHICKEN KORMA

Serves 4

225g korma paste*
15ml (1 tbsp) cornflour
150ml (1/4 pint) hot chicken stock
125g onion, chopped
900g Chicken, diced
300g (1/2 pint) coconut cream
50g creamed coconut

- 1 Mix the paste and cornflour together in a 2.5 litre (approx. 4 pints) casserole dish, gradually stirring in the stock.
- 2 Add all the other ingredients, stirring well.
- 3 Place on the turntable. **Do not cover.**
- 4 Cook on 70P for 30 minutes.
- 5 Stir 2-3 times during cooking.

Note

* Before using the Korma paste, ensure the oil is poured from the top of the jar, then drain the paste, using a sieve with kitchen paper in it to remove the remaining excess oil.

RECIPES

GARLIC CHICKEN

Serves 4-6

150g green peppers, chunks
150g red peppers, chunks
150g yellow peppers, chunks
head of garlic, separate cloves and peel
150g celery, sliced
800g chicken fillets, cubed
400g chopped tomatoes, canned
5ml (1 tsp) caster sugar
10ml (2 tsp) fresh basil, chopped
salt and pepper to taste

- 1 Place the peppers, garlic, celery and chicken into a 2.5 litre (approx. 4 pints) bowl and cook on 100P for 4 minutes.
- 2 Add the remaining ingredients and mix well.
- 3 Place on the turntable and cook on 70P for 25 minutes, stirring 2-3 times during cooking.

Garnish with black olives and fresh basil.

VEGETABLE COUS COUS

Serves 4-6

300g carrots, sliced
200g leeks, sliced
150g red peppers, chopped
150g canned sweetcorn
900ml (1 1/2 pints) hot vegetable stock
250g cous cous

- 1 Place the carrots, leeks, peppers, sweetcorn and stock into a 2.5 litre (4 pint) casserole dish, mix well and cook on 70P for 20 minutes, stirring twice.
- 2 Add the cous cous, mix well and cook on 70P for 5 minutes.

Serve hot as an accompaniment or cold as a salad.

BEAN CASSEROLE

Serves 4

200g courgettes, sliced
150g leeks, sliced
2 clove garlic, crushed
800g canned, chopped tomatoes
600g canned, mixed beans in curry sauce
150g fresh baby sweetcorn, chopped
5ml (1 tsp) fennel seeds
3 vegetable stock cubes
salt and pepper to taste

- 1 Place the courgettes, leeks and garlic in a 2.5 litre (4 pint) casserole dish, mix well.
- 2 Add the tomatoes, beans, sweetcorn, fennel and stock cubes. Season and mix well.
- 3 Cook on 70P for 15 minutes, then on 100P for 15 minutes, stir 2-3 times during cooking.

Serve with rice or baked potatoes.

SPICY POTATOES

Serves 4

30ml vegetable oil
10ml ground cinnamon
10ml ground coriander
5ml cayenne pepper
10ml sesame seeds
10ml caraway seeds
50g butter
1.3cm (1/2") fresh root ginger, peeled & grated
2 cloves garlic, crushed
675g cooked potatoes, cut into 2.5cm (1") pieces
pinch of salt

- 1 Place the oil, cinnamon, coriander, cayenne pepper, sesame and caraway seeds in a 2.5 litre (approx. 4 pint) casserole dish, mix well. Heat on 100P for 1 minute.
- 2 Add the butter, ginger and garlic. Cook on 70P for 3 minutes. Stir in the potatoes and salt.
- 3 Place the dish on the turntable, cook on 70P for 8 minutes, stir twice.

Garnish with fresh chopped coriander, serve with grilled or roasted meats.

RECIPES

CHEESE & POTATO LAYER

Serves 4

300g leeks, sliced
200g cooked ham, chopped
200g par-boiled potatoes, thinly sliced
600ml (1 pint) white sauce (See below)
250g cheddar cheese, grated

- 1 Mix the leeks and ham in bowl, cook on 100P for 5 minutes.
- 2 Place half the leek mixture in a 2.5 litre (approx. 4 pint) casserole dish cover with half the potato slices, pour over half the sauce and sprinkle with half the cheese. Repeat with the remaining ingredients.
- 3 Cook on 70P for 30 minutes.

WHITE SAUCE

300ml (1/2 pint)
25g margarine
25g plain flour
300ml (1/2 pint) milk
salt and pepper to taste

- 1 Place the margarine in a bowl and heat on 100P for 30 seconds, until melted.
- 2 Stir in the flour and whisk in the milk. Cook on 100P for 6 minutes, stirring halfway through cooking, until thick and smooth. Season with salt and pepper to taste.

Variations:

Cheese sauce:

Stir in 75g grated cheese and 5ml (1 tsp) mustard powder at Stage 2. Serve with vegetables, fish or meat.

Parsley sauce:

Stir 15-30ml (1 - 2 tbsp) fresh, chopped parsley into the finished sauce. Serve with fish.

Onion sauce:

Add 225g cooked onion, finely chopped into the sauce at stage 2. Serve with vegetables.

Sweet white sauce:

Omit salt and pepper from basic recipe. Add 15 - 30ml (1 - 2 tbsp) caster sugar at Stage 2. Serve with puddings as an alternative to custard.

RICE PUDDING

Serves 4

1500ml (2 1/2 pints) milk
200g pudding rice
150g caster sugar
5ml (1 tsp) ground nutmeg (optional)

- 1 Place the milk in a 2.5 litre (approx. 4 pint) casserole dish. Heat on 100P for 8 minutes.
- 2 Stir in the rice and sugar.
- 3 Place on the low rack, cook on 50P for 60 minutes, stir 3 times during cooking and again at the end of cooking.
- 4 Sprinkle with ground nutmeg to serve.

FRUIT CRUMBLE

Serves 4

750g seasonal fresh fruit, lightly cooked
100g brown sugar
5ml (1 tsp) cinnamon
150g plain wholemeal flour
75g rolled oats
75g margarine

- 1 Place the fruit, 50g of the brown sugar and the cinnamon in a dish, mix well and cook on 100P for 4 minutes.
- 2 Place flour and oats in bowl, mix well and rub in margarine, until mixture resembles fine breadcrumbs. Add remaining brown sugar, mix well. Sprinkle over the fruit and cook on 50P for 10 minutes.

RECIPES

GINGER CAKE

Serves 4 - 6 (800g)

200g caster sugar

200g margarine

4 eggs (medium)

200g self raising flour

2" piece, fresh stem ginger, grated

20ml (4 tsp) ground ginger

60ml (4 tbsp) orange juice

topping: 225g cream cheese
grated rind of 1 orange
5ml (1 tsp) orange juice
30ml (2 tbsp) icing sugar

- 1 Cream the sugar and margarine until light and fluffy.
 - 2 Beat in the eggs one at a time.
 - 3 Sift the flour and fold into the mixture.
 - 4 Add the grated fresh ginger, ground ginger and orange juice then mix to a dropping consistency.
 - 5 Spoon the mixture into a greased and lined 8" (21cm x 9.5cm) deep cake dish.
 - 6 Cook using **Express Cook EC-8 "Cake"**.
 - 7 Leave to stand for 10 minutes.
 - 8 To prepare the topping, combine the cream cheese, orange juice and icing sugar until smooth. Spread on top of the cake.
- Keep refrigerated.**

COFFEE & ALMOND CAKE

Serves 4-6 (800g)

200g caster sugar

200g margarine

4 eggs (medium)

200g self raising flour

5ml (1 tsp) almond essence

20ml (4 tsp) instant coffee

45ml (3 tbsp) hot water

topping: 100g icing sugar
15ml (1 tbsp) water
25g almonds
25g glace cherries

- 1 Cream the sugar and margarine until light and fluffy.
 - 2 Beat in the eggs one at a time.
 - 3 Sift the flour and fold into the mixture.
 - 4 Dissolve the coffee in the hot water and fold into the mixture, together with the almond essence.
 - 5 Spoon into a greased and lined 8" (21cm x 9.5cm) deep cake dish.
 - 6 Cook using **Express Cook EC-8 "Cake"**.
 - 7 Leave to stand for 10 minutes.
 - 8 Mix the icing sugar and water to make a smooth paste.
- Drizzle over the cake and sprinkle with the almonds and cherries.
- Keep refrigerated.**

DOUBLE CHOC-CHIP CAKE

Serves 4-6 (800g)

200g caster sugar

200g margarine

4 eggs (medium)

100g self raising flour

50g cocoa powder

75g plain or milk chocolate drops

- 1 Cream the sugar and margarine until light and fluffy.
 - 2 Beat in the eggs one at a time.
 - 3 Sift the flour and cocoa powder then fold into the mixture.
 - 4 Add chocolate drops and stir well.
 - 5 Spoon into a greased and lined 8" (21cm x 9.5cm) deep cake dish.
 - 6 Cook using **Express Cook EC-8 "Cake"**.
- Leave to stand for 10 minutes.

CLEANING & MAINTENANCE

OVEN INTERIOR

- It is important to clean the interior of your microwave oven after each use.
- To clean the oven interior, use a mild detergent solution, such as washing-up liquid, with warm water on a soft cloth.
- Food and liquid splashes will build-up on the oven walls and ceiling. If grease, fat and food debris is allowed to build-up in the oven interior it may overheat, smoke or even catch fire when next using the oven.
- Keep the **waveguide cover** clean at all times. The waveguide cover is constructed from a fragile material and should be cleaned with care (follow the cleaning instructions above).
NOTE: Excessive soaking may cause disintegration of the waveguide cover. The waveguide cover is a consumable part and without regular cleaning, will need to be replaced.
- Food will release steam during cooking and cause condensation inside the oven and door. It is important to wipe the oven dry. A build-up of condensation will eventually lead to rust forming on the oven interior.
- **Do not allow grease or dirt to build-up on the door seals or areas around the door. This may prevent the door from closing correctly and may cause a leakage of microwaves (follow the cleaning instructions opposite).**
- Ensure the turntable and roller stay are cleaned after every use with a mild washing-up liquid solution and dried. This will prevent the build-up of grease and food debris. The turntable is dishwasher safe.
- **CLEAN THE OVEN AT REGULAR INTERVALS AND REMOVE ANY FOOD DEPOSITS.**
Failure to maintain the oven in a clean condition could lead to a deterioration of the surface that could adversely affect the life of the appliance and possibly result in a hazardous situation.

OUTER CABINET

- Wipe the outside of the microwave oven with a mild detergent solution, such as washing-up liquid, with warm water on a soft cloth.
- The control panel must be wiped clean and dried with the door open, therefore inactivating the oven.

NOTES:

- Never use spray cleaners, oven pads or abrasive scourers as these damage the surface of the oven.
- A steam cleaner should not be used.
- Take care not to let soapy water drip through the small holes in the oven walls and the cavity floor. Excess water spillage through these holes will cause damage to the oven interior.

TROUBLESHOOTING

If you think the oven is not working properly there are some simple checks you can carry out yourself before calling an engineer. This will help prevent unnecessary service calls if the fault is something simple.

Follow this simple check below:

Place half a cup of water on the turntable and close the door. Select HIGH and programme the oven to cook for 1 minute.

1. Does the oven lamp come on when it is cooking?
2. Does the turntable rotate?
3. Does the cooling fan work? (Check by placing your hand above the air vent openings.)
4. After 1 minute does the audible signal sound?
5. Is the water in the cup hot?

If you answer "NO" to any question first check that the oven is plugged in properly and the fuse has not blown. If there is no fault with either, check against the chart below.

NOTE:

If you cook food for more than the standard time (see chart below) using the same cooking mode, the oven's safety mechanisms automatically activate. The microwave power level will be reduced.

Cooking Mode	Standard Time
Microwave HIGH cooking	20 Minutes

WARNING:

Never adjust, repair or modify the oven yourself. It is hazardous for anyone other than a SHARP trained engineer to carry out servicing or repairs.

This is important as it may involve the removal of covers that provide protection against microwave energy.

- The door seal stops microwave leakage during oven operation, but does not form an airtight seal. It is normal to see drops of water, light or feel warm air around the oven door. Food with a high moisture content will release steam and cause condensation inside the door which may drip from the oven.
- Repairs and Modifications: Do not attempt to operate the oven if it is not working properly.
- Outer Cabinet & Lamp Access: Never remove the outer cabinet. This is very dangerous due to high voltage parts inside which must never be touched, as this could be fatal. Your oven is not fitted with a lamp access cover. If the lamp fails, do not attempt to replace the lamp yourself, call a SHARP approved service facility.

QUERY	ANSWER
Draught circulates around the door.	When the oven is working, air circulates within the cavity. The door does not form an airtight seal so air may escape from the door.
Condensation forms in the oven, and may drip from the door.	The oven cavity will normally be colder than the food being cooked, and so steam produced when cooking will condense on the colder surface. The amount of steam produced depends on the water content of the food being cooked. Some foods, such as potatoes have a high moisture content. Condensation trapped in the door glass should clear after a few hours.
Flashing or arcing from within the cavity when cooking.	Arcing will occur when a metallic object comes into close proximity to the oven cavity during cooking. This may possibly roughen the surface of the cavity, but would not otherwise damage the oven.
Arcing potatoes.	Ensure all "eyes" are removed and the potatoes have been pierced, place directly onto the turntable or in a heat resistant flan dish or similar.
The display is lit but the control panel will not work when pressed.	Check the door is closed properly.
Oven cooks too slowly.	Ensure correct power level has been selected.
Oven makes a noise.	The microwave energy pulses ON and OFF during cooking/defrosting.
Outer cabinet is hot.	The cabinet may become warm to the touch - keep children away.

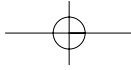

TO REPLACE THE MAINS PLUG

The wires in the mains cable are colour coded as shown:

Green and yellow stripes = **EARTH**
 Blue = **NEUTRAL**
 Brown = **LIVE**

As the colours in the mains lead of your oven may not correspond with the coloured marking identifying the terminals in your plug, connect the wires as described:

- The green and yellow wire to the plug terminal marked E or  or coloured green or coloured green and yellow.
- The blue wire to the plug terminal marked N or coloured black or coloured blue.
- The brown wire to the plug terminal marked L or coloured red or coloured brown.

Make sure the terminal screws are tight and the cable is held securely by the cable grip where it enters the plug.

Like most appliances in your home, your oven must be connected to a single phase 230-240V, 50Hz alternating current supply.

If you do not make the proper electrical connections you might damage the oven or injure yourself. Neither SHARP nor the supplier will be liable if this happens.



WARNING: THIS APPLIANCE MUST BE EARTHED

If you have any doubts about your electrical supply ask a qualified electrician.

CALLING FOR SERVICE

- If you are unable to resolve a problem using the checks covered on the last few pages, **do not attempt to service this microwave oven yourself.**
- Contact the dealer or supplier from whom the oven was purchased in order to obtain service. Where this is not possible, please contact the SHARP Customer Information Centre. Telephone: 08705 274277 (office hours).
- For general information and assistance with oven queries, please contact our **Customer Information Centre:**
U.K.: 08705 274277 (office hours)
Ireland: 01 676 0648 (office hours)
Website: <http://www.sharp.co.uk/support>
- Replacement accessories may be obtained from our main parts distributor: Willow Vale Electronics Ltd. Telephone: 0121 766 5414

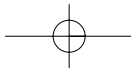

GUARANTEE

Sharp Electronics (UK) Ltd. ("Sharp") guarantees that for a period of 12 months from the date of purchase the enclosed product will be free from defects in materials and workmanship. Sharp agrees to provide for the repair or, at its option, the replacement of a defective product. Sharp reserves the right to replace defective parts, or the product, with new or refurbished items. Items that are replaced become the property of Sharp.

To benefit from this guarantee, any fault that occurs must be notified to Sharp, or its appointed Service Facility, within one year from the date the product was purchased. Proof of purchase, such as a receipt or invoice, must be provided.

If the product is exchanged, the replacement shall be covered by the unexpired portion of the original guarantee.

In the unlikely event of the product requiring repair, please contact the supplier from whom it was purchased. Where this is not possible, please contact an appointed Service Facility. Details of Service Facilities appointed by Sharp can be obtained from www.sharp.co.uk/customersupport/service or by contacting the **Sharp Customer Information Centre** whose details are given below.

This guarantee shall only apply to faults that are due to inferior workmanship or materials. It does not cover faults or damage caused by accident, misuse, fair wear and tear, neglect, tampering with the product, or repair other than by a Service Facility appointed by Sharp.

The product is intended for private domestic use only. The guarantee will not apply if the product is used in the course of a business, trade or profession.

The guarantee does not cover:

- Glass/ceramic turntables, as they can be damaged by handling/cleaning methods.
- Faults resulting from inadequate cleaning. Regular cleaning is required to prevent a build up of food residue that can also affect the performance of the product.
- Carriage costs to or from the repair centre.

No person has any authority to vary the terms or conditions of this guarantee.

This guarantee is offered as an additional benefit to your statutory rights, and does not affect these rights in any way.

You may not transfer your rights or obligations under this warranty to anyone else.

If you have any difficulty operating the product, or would like information on other Sharp products, please telephone the Sharp Customer Information Centre on the number given below.

Sharp Customer Information Centre

Website: www.sharp.co.uk/customersupport

Telephone: 08705 274277 (01 676 0648 in Southern Ireland)

Sharp Electronics (UK) Ltd is a company registered in England under number 965877
whose registered office is at
Sharp House, Thorp Road, Newton Heath, Manchester, M40 5BE.

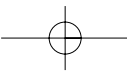

SPECIFICATIONS

AC Line Voltage	Single phase 230-240V, 50Hz
Power Consumption:	
Microwave	1.22kW
Input Current:	
Microwave	5.2A
Output Power:	
Microwave	800W (IEC 60705)
MAFF Heating Category	E
Microwave Frequency	2450Mhz* (Group 2/Class B)
Outside Dimensions	460(W) x 275(H) x 380(D)mm
Cavity Dimensions	319(W) x 211(H) x 336(D)mm**
Oven Capacity	22 litres**
Cooking Uniformity	Turntable diameter 272mm
Weight	Approx. 12kg

* This Product fulfils the requirement of the European standard EN55011. In conformity with this standard, this product is classified as group 2 class B equipment. Group 2 means that the equipment intentionally generates radio-frequency energy in the form of electromagnetic radiation for the heat treatment of food. Class B equipment means that the equipment is suitable to be used in domestic establishments.

** Internal capacity is calculated by measuring maximum width, depth and height. Actual capacity for holding food is less.

This oven complies with the requirements of Directives 89/336/EEC and 73/23/EEC as amended by 93/68/EEC.

As part of a policy of continuous improvement, we reserve the right to alter design and specifications without notice.

No part of this publication may be reproduced, stored in a retrieval system or transmitted in any form, electronic, mechanical, photocopying, recording, translating or other means without prior permission from SHARP Electronics (U.K.) Ltd.

The illustrations, technical information and data contained in this publication are, to our best knowledge, correct at the time of going to print. The right to change specifications, at any time, without notice, is reserved as a part of our policy of continuous development and improvement.

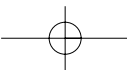

SHARP

Sharp Electronics (U.K.) Ltd
Manchester, U. K.

U.K.: 08705 274277 (office hours)

Ireland: 01 676 0648 (office hours)

Website: <http://www.sharp.co.uk/support>

PRINTED IN THAILAND
TINSEBI06WRRZ-K52